

The Building Regulations 2000

Sanitation, hot water safety and water efficiency

G

APPROVED DOCUMENT

- G1 Cold water supply**
- G2 Water efficiency**
- G3 Hot water supply and systems**
- G4 Sanitary conveniences and washing facilities**
- G5 Bathrooms**
- G6 Kitchens and food preparation areas**

DRAFT

2009 edition

MAIN CHANGES IN THE 2009 EDITION

1. This Approved Document G (2009) comes into force on 1 October 2009 in support of the Building Regulations 2000 (SI 2000/2531) and the Building (Approved Inspectors etc.) Regulations 2000 (SI 2000/2532) as amended, in particular the amendments made by the Building and Approved Inspectors (Amendment) Regulations 2009 (SI 2009/1219). From 1 October 2009 the 2000 edition of Approved Document G will no longer be valid except where it continues to apply in consequence of the transitional provisions in SI 2009/1219.

Changes in the legal requirements

2. The main legal changes are mentioned here and are also reproduced in the relevant text for ease of reference. In cases of doubt reference should be made to the relevant regulations themselves.
3. Parts G1 to G6 are significantly different from the former requirements in Part G:
 - There is in G1 a new requirement on the supply of wholesome water for the purposes of drinking, washing or food preparation.
 - G1 also allows the provision of water of a suitable quality to sanitary conveniences.
 - G2 and Regulation 17K set out new requirements on water efficiency in dwellings.
 - G3 sets out enhanced and amended provisions on hot water supply and safety, applying safety provisions to all types of hot water systems and a new provision on the prevention of scalding.
 - G4 sets out the requirements for sanitary conveniences and hand washing facilities.
 - G5 sets out requirements for bathrooms, which apply to dwellings and to buildings containing one or more rooms for residential purposes.
 - G6 contains a new provision requiring sinks to be provided in areas where food is prepared.
4. The provisions on material change of use have been amended to reflect the changes made to Part G. In particular, where there is a material change of use to create a new dwelling in an existing building, either by converting a non-domestic building or by the provision of a flat or flats in a building, the water efficiency requirements in G2 and Regulation 17K will apply as will the hot water safety requirement in G3(4).

5. The requirements in G1 (cold water supply) and hot water supply and systems in G3 have been extended to domestic greenhouses, small detached buildings and extensions to buildings, in particular to conservatories.
6. The requirement that a building notice which includes work on an unvented hot water system be accompanied by a statement giving certain details of the unvented hot water system and the installer has been revoked.
7. Regulation 17 of the Building Regulations has been amended to the effect that a local authority cannot give a completion certificate until it has received in respect of new dwellings a certificate specifying the calculated potential consumption of wholesome water per person per day.

Changes in the technical guidance

8. G3 Hot water supply and systems

- a. G3(1) is a new requirement that embodies the need to provide hot water to baths, showers, washbasins and sinks.
- b. G3(2) is a new requirement that extends measures to ensure safe operation of all types of hot water systems. It includes controls and other safety devices to prevent the temperature exceeding 100°C, and robust installation.
- c. G3(3) embodies the previous requirement G3, and applies it now to all hot water storage systems. Its scope has been extended to include primary thermal stores.
- d. G3(4) is a new requirement for the prevention of scalding through the installation of protective devices that limit the temperature of water supplied to fixed baths.

9. G4 Sanitary conveniences and washing facilities

Previously G1, reference is made to the Approved Code of Practice for workplaces that supports the Workplace (Health, Safety and Welfare) Regulations 1992. Additional guidance is provided on the separation of sanitary accommodation from places used for the preparation of food.

Contents

	PAGE		PAGE
Introduction	3	G3: Hot water supply and systems	17
What is an Approved Document?	3	The requirement	17
Consideration of technical risk	3	Guidance	18
How to use this Approved Document	4	Performance	18
Where you can get further help	4	General	18
Responsibility for compliance	4	Provision of hot water supply	19
The requirements	5	Design and installation of directly or indirectly heated hot water storage systems	19
Limitation on requirements	5	Safety devices	21
General guidance	6	Electric water heating	22
Key terms	6	Solar water heating	22
Types of work covered by this Approved Document	7	Discharge pipe from safety devices	22
Material change of use	8	Prevention of excessive temperatures	25
Historic buildings	8	Prevention of scalding	25
Notification of work	8	Installation	25
Exemptions	9	Commissioning of fixed building services	25
Materials and workmanship	10	Notice of completion of commissioning	26
Supplementary guidance	10	G4: Sanitary conveniences and washing facilities	27
Technical specifications	10	The requirement	27
Independent schemes of certification and accreditation	11	Guidance	28
Interaction with other legislation	11	Performance	28
G1: Cold water supply	12	General	28
The requirement	12	Scale of provision and layout in dwellings	28
Guidance	13	Scale of provision and layout in buildings other than dwellings	29
Performance	13	Chemical and composting toilets	30
Wholesome water (all buildings)	14	Discharges to drains	30
Non-wholesome water (all buildings)	14	G5: Bathrooms	31
G2: Water efficiency	15	The requirement	31
The requirement	15	Guidance	32
Guidance	16	Performance	32
Performance	16	General	32
General	16	Scale of provision and layout in dwellings	32
Notification of water efficiency calculation to the BCB	16	Scale of provision and layout in buildings with rooms for residential purposes	32
		Discharges to drains	32

	PAGE
G6: Food preparation areas	33
The requirement	33
Guidance	34
Performance	34
Scale of provision in dwellings	34
Scale of provision in buildings other than dwellings	34
Discharges to drains	34
Annex 1: Wholesome water	35
Annex 2: Competent person self-certification schemes relevant to sanitation, hot water safety and water efficiency work	37
Annex 3: References	38
Approved Documents	38
Relevant legislation	38
Standards	38
Other documents	39
DIAGRAMS	
1. Typical discharge pipe arrangement	23
2. Separation between hand washbasin/WC and food preparation area – single room	29
3. Separation between hand washbasin/WC and food preparation area – two rooms	29
TABLES	
1. Sizing of copper discharge pipe 'D2' for common temperature relief valve outlet sizes	24

Introduction

What is an Approved Document?

This document has been approved and issued by the Secretary of State to provide practical guidance on ways of complying with Requirements G1 to G6 and regulations 7 and 17K of the Building Regulations 2000 (SI 2000/2531 as amended) for England and Wales, as amended. The Building Regulations 2000 are referred to throughout the remainder of this Document as 'the Building Regulations'. Where appropriate the Approved Document also gives guidance on relevant requirements in the Building (Approved Inspectors etc.) Regulations 2000 (SI 2000/2532), as amended.

The intention of issuing Approved Documents is to provide guidance about compliance with specific aspects of the Building Regulations in some of the more common building situations. They set out what, in ordinary circumstances, would be reasonable provision for compliance with the relevant requirement(s) of the Building Regulations to which they refer.

If guidance in an Approved Document is followed there will be a presumption of compliance with the requirement(s) covered by the guidance. However, this presumption is not conclusive, so simply following guidance does not guarantee compliance in an individual case. It is also important to note that there may well be other ways of achieving compliance with the requirements. There is therefore no obligation to adopt any particular solution contained in this Approved Document if you would prefer to meet the relevant requirement in some other way. However, persons intending to carry out building work should always check with their Building Control Body (BCB), either the local authority or an Approved Inspector, that their proposals comply with Building Regulations.

The guidance contained in this Approved Document relates only to the particular requirements of the Building Regulations that the document addresses (see 'Requirements' below). However, building work may be subject to more than one requirement of the Building Regulations. In such cases the work will also have to comply with any other applicable requirements of the Building Regulations.

This document is one of a series that has been approved and issued by the Secretary of State for the purpose of providing practical guidance with respect to the requirements of Schedule 1 and regulation 7 of the Building Regulations 2000 (SI 2000/2531) for England and Wales.

SI 2000/2531 has been amended by the following regulations:

The Building (Amendment) Regulations 2009 (SI 2009/466)

The Energy Performance of Buildings (Certificates and Inspections) (England and Wales) (Amendment No.2) Regulations 2008 (SI 2008/2363)

The Building (Amendment) Regulations 2008 (SI 2008/671)

The Building and Approved Inspectors (Amendment) Regulations 2007 (SI 2007/3384)

The Energy Performance of Buildings (Certificates and Inspections) (England and Wales) Regulations 2007 (SI 2007/991)

The Building and Approved Inspectors (Amendment) (No.2) Regulations 2006 (SI 2006/3318)

The Building and Approved Inspectors (Amendment) Regulations 2006 (SI 2006/652)

The Building (Amendment) (No.3) Regulations 2004 (SI 2004/3210)

The Building (Amendment) Regulations 2004 (SI 2004/1465)

The Building (Amendment) Regulations 2003 (SI 2003/2692)

The Building (Amendment) (No.2) Regulations 2002 (SI 2002/2871)

The Building (Amendment) Regulations 2002 (SI 2002/440)

The Building (Amendment) Regulations 2001 (SI 2001/3335)

At the back of this document is a list of all the documents that have been approved and issued by the Secretary of State for this purpose.

Consideration of technical risk

In relation to the installation of new and replacement sanitation and hot water services, building work must satisfy all the technical requirements set out in Schedule 1 to the Building Regulations. Attention should be paid in particular to the need to comply with Part A (Structure), Part B (Fire safety), Part C (Site preparation and resistance to contaminants and moisture), Part J (Combustion appliances and fuel storage systems), Part L (Conservation of fuel and power) and Part P (Electrical safety), as well as Part G.

How to use this Approved Document

In this document the following conventions have been adopted to assist understanding and interpretation:

- a. Texts shown against a green background are extracts from the Building Regulations or Building (Approved Inspectors etc.) Regulations, both as amended, and set out the legal requirements that relate to compliance with the sanitation, hot water safety and water efficiency requirements of Building Regulations. It should be remembered however that, as noted above, building works must comply with all the other applicable provisions of Building Regulations.
- b. Key terms are defined below and are printed in **bold italic text**.
- c. Details of technical publications referred to in the text of this document will be given in footnotes and repeated as end notes. A reference to a publication is likely to be made for one of two main reasons. The publication may contain additional or more comprehensive technical detail, which it would be impractical to include in full in this Document but which is needed to fully explain ways of meeting the requirements; or it is a source of more general information. The reason for the reference will be indicated in each case. The reference will be to a specified edition of the document. The Approved Document may be amended from time to time to include new references or to refer to revised editions where this aids compliance.

Where you can get further help

If you do not understand the technical guidance or other information set out in this Approved Document and the additional detailed technical references to which it directs you, there are a number of routes through which you can seek further assistance:

- The Communities and Local Government website: www.communities.gov.uk
- The Planning Portal website: www.planningportal.gov.uk
- If you are the person undertaking the building work you can seek assistance either from your local authority building control service or from your approved inspector (depending on which building control service you are using, or intend to use, to certify compliance of your work with the requirements of the Building Regulations).
- Businesses registered with a competent person self-certification scheme may be able to get technical advice from their scheme operator.
- If your query is of a highly technical nature you may wish to seek the advice of a specialist, or industry technical body, in the area of concern.

Responsibility for compliance

It is important to remember that if you are the person (e.g. designer, builder, installer) carrying out building work to which any requirement of Building Regulations applies you have a responsibility to ensure that the work complies with any such requirement. The building owner may also have a responsibility for ensuring compliance with Building Regulation requirements and could be served with an enforcement notice in cases of non-compliance.

The requirements

This Approved Document, which takes effect on 1 October 2009, deals with the sanitation, hot water safety and water efficiency requirements in the Building Regulations 2000 (as amended).

Limitation on requirements

In accordance with regulation 8 of the Building Regulations, the requirements in Parts A to D, F to K and N and P (except for paragraphs G2, H2 and J6) of Schedule 1 to the Building Regulations do not require anything to be done except for the purpose of securing reasonable standards of health and safety for persons in or about buildings (and any others who may be affected by buildings or matters connected with buildings).

Paragraph G2 is excluded from regulation 8 as it deals with the conservation of water. Paragraphs H2 and J6 are excluded from regulation 8 because they deal directly with prevention of the contamination of water and of oil pollution. Parts E and M (which deal, respectively, with resistance to the passage of sound, and access to and use of buildings) are excluded from regulation 8 because they address the welfare and convenience of building users. Part L is excluded from regulation 8 because it addresses the conservation of fuel and power. All these matters are amongst the purposes, other than health and safety, that may be addressed by Building Regulations.

General guidance

Key terms

The following are key terms used in this document:

Note: Terms shown with * are defined in legislation, either in the Building Act 1984 or the Building Regulations 2000, where the definition may be fuller than the definition given here.

BCB means Building Control Body: a local authority or an Approved Inspector.

***Building** means any permanent or temporary building, but not any other kind of structure or erection, and a reference to a building includes a reference to part of a building. This includes dwellings (houses, flats) and public buildings.

***Building work** includes the erection or extension of a **building**, the provision or extension of a **controlled service or fitting** in or in connection with a building, and the **material alteration** of a building, or a controlled service or fitting.

Combined temperature and pressure relief valve means a mechanically operated valve that opens to discharge water when a fixed (factory set) temperature or fixed (factory set) pressure is exceeded.

Controlled service or fitting includes a service or fitting subject to Schedule 1 requirements in respect of sanitation, hot water safety, water efficiency, drainage and waste disposal, combustion appliances and fuel storage, conservation of fuel or power, and electrical safety.

Direct heating means a method of heating in which the heat source is integral with the hot water vessel. Examples are an electrical immersion heater, or a gas burner with a flue arrangement that passes through the vessel so that the flue transfers heat to the stored water, or the circulation of water from a vessel situated near a burner with a flue arrangement so that the flue transfers heat to the circulating water.

Domestic hot water means water that has been heated for cooking, food preparation, personal washing or cleaning purposes. The term is used irrespective of the type of **building** in which the hot water system is installed.

***Earth-closet** means a closet having a movable receptacle for the reception of faecal matter and its deodorisation by the use of earth, ashes or chemicals, or by other methods. This will therefore include chemical and composting toilets.

Exempt buildings and work means the erection of any building or extension of a kind described in Regulation 9 and Schedule 2 of the Buildings Regulations 2000; or the carrying out of any work to or in connection with such a building or extension, if after the carrying out of that work it is still a building or extension of a kind described in that Schedule.

Expansion vessel means a vessel to temporarily accommodate the expansion of water from the unvented hot water storage vessel as it is heated.

Greywater is domestic wastewater excluding faecal matter and urine. When appropriately treated this may replace the use of **wholesome water** in **WCs, urinals**, irrigation or washing machines.

Harvested rainwater means rainwater harvested from roofs or other suitable surfaces and collected and stored. When appropriately treated, this may replace the use of **wholesome water** in **WCs, urinals**, irrigation or washing machines.

Heated wholesome water means water that, when cold, was wholesome in accordance with the definition below and has been subjected to a heat source to increase its temperature.

Hot water storage system means a vessel for storing:

- heated **wholesome hot water** for subsequent use
- water that is used to heat other water

together with any ancillary safety devices described in paragraphs 3.10 and 3.11 of this Approved Document and all other applicable operating devices.

Hot water storage system package means a **hot water storage system** having the safety devices described in 3.10 and 3.17 of this Approved Document factory-fitted by the manufacturer, together with a kit containing other applicable devices supplied by the manufacturer to be fitted by the installer.

Hot water storage system unit means a **hot water storage system** having the safety devices described in 3.10 and 3.17 of this Approved Document and all other applicable operating devices factory-fitted by the manufacturer.

Indirect heating means a method of heating stored water through a heat exchanger.

Kitchen means a room or part of a room which contains a **sink** and food preparation facilities

Material alteration means an alteration which results in a **building** or a **controlled service or fitting** not complying with, or being more **unsatisfactory** than it was before in relation to Schedule 1 requirements in relation to structure, means of warning and escape, internal and external fire spread, fire service access and facilities, and access and use.

Non-self-resetting energy cut-out means a device that will interrupt the supply of heat to a hot water storage vessel when a fixed (factory set) temperature is exceeded. If this protective device is actuated it should only be possible to reset it manually after removal of a cover. Such a cover should be removable only with a tool.

Non-wholesome water means water that does not meet the requirements for **wholesome water**, but is considered suitable for certain applications having regard to the risks to human health. This could include **greywater** or **harvested rainwater**.

Preparation of food means handling, making and cooking of food.

Pressure relief valve means a mechanically operated valve that opens to discharge water when a fixed (factory set) pressure is exceeded.

Primary thermal store means a store of heat energy that can be used to heat **domestic hot water** by means of a heat exchanger. The thermal store can be heated by a variety of heat sources. Primary hot water thermal stores can be either vented or unvented.

Risk assessment for the purposes of this document means the identification of the hazards associated with a process or activity combined with an assessment of the probability and consequences of each hazard.

***Room for residential purposes** means a room, or a suite of rooms, which is not a dwelling-house or a flat and which is used by one or more persons to live and sleep in, and includes a room in a hostel, a hotel, a boarding house, a hall of residence or a residential home, whether or not the room is separated from or arranged in a cluster group with other rooms, but does not include a room in a hospital, or other similar establishment, used for patient accommodation and, for the purposes of this definition, a 'cluster' is a group of rooms for residential purposes which is (a) separated from the rest of the **building** in which it is situated by a door which is designed to be locked; and (b) not designed to be occupied by a single household.

Sanitary accommodation means a room containing a **WC** or **urinal**, whether or not it also contains other **sanitary appliances**. Sanitary accommodation containing one or more cubicles counts as a single space if there is free circulation of air throughout the space.

Sanitary appliance means **WC**, **urinal**, bath, shower, washbasin, **sink**, bidet and drinking fountain. It also includes appliances that are not connected to a water supply (e.g. composting toilet) or drain (e.g. waterless **urinal**).

***Sanitary convenience** means closets and **urinals**.

Sink means a receptacle used for holding water (for **preparation of food** or washing up) supplied through a tap and having a wastepipe.

Tundish means a device, installed in the discharge pipe from a valve, that provides an air break allowing discharge to be conducted safely to a place of termination. The tundish also provides a visible indication of a discharge and functions as backflow prevention device.

Temperature relief valve means a mechanically operated valve that opens to discharge water when a fixed (factory set) temperature is exceeded.

Unvented (closed) hot water storage system means a vessel fed with cold water from a supply pipe or dedicated storage cistern (without a vent pipe) and in which water is heated directly or indirectly. Expansion of the water when it is heated is accommodated either internally or externally and the system is fitted with safety devices to prevent water temperatures exceeding 100°C, and other applicable operating devices to control primary flow, prevent backflow, control working pressure and accommodate expansion.

Urinal means an appliance used for reception and disposal of urine.

Vented (open) hot water storage system means a vessel fed with cold water from a dedicated storage cistern. Expansion of the water when it is heated is accommodated through the cold feed pipe. A vent pipe connecting the top of the vessel to a point open to the atmosphere above the cold water storage cistern is provided as a safety device.

***Water-closet (WC)** means a closet that has a separate fixed receptacle connected to a drainage system and separate provision for flushing from a supply of clean water either by the operation of a mechanism or by automatic action. Water-closets are also referred to as WCs.

Wholesome water means water complying with the requirements of regulations made under Section 67 (Standards of wholesomeness) of the Water Industry Act 1991. The regulations made under this Section at the time of publication of this Approved Document are the Private Water Supplies Regulations 1991 (SI 1991/2790) and, for England, the Water Supply (Water Quality) Regulations 2000 (SI 2000/3184 as amended), and, for Wales, the Water Supply (Water Quality) Regulations 2001 (SI 2001/3911 as amended).

Types of work covered by this Approved Document

Building work

Building work, as defined in Regulation 3 of the Building Regulations 2000, includes the erection and extension of a building, the provision or extension of a controlled service or fitting, and the material alteration of a building or a controlled service or fitting. In addition, Building Regulations may apply in cases where the purposes for which or the manner or circumstances in which a building or part of a building is used change in a way that constitutes a material change of use.

Under regulation 4 of the Building Regulations 2000 (as amended), building work should be carried out in such a way that, on completion of work,

- i. the building complies with the applicable Parts of Schedule 1 of the Building Regulations,
- ii. in the case of an extension or material alteration of a building, or the provision, extension or material alteration of a controlled service or fitting, where it did not comply with any such requirement, it is no more unsatisfactory in relation to that requirement than before the work was carried out.

Work described in Part G concerns the provision or extension of controlled services or fittings. Work associated with installations covered in these sections may be subject to other relevant Parts of the Building Regulations.

Material change of use

A material change of use occurs in specified circumstances in which a building or part of a building that was previously used for one purpose will be used in future for another. Where there is a material change of use the Building Regulations set requirements that must be met before the building can be used for its new purpose.

Regulation 5 of the Building Regulations specifies the following circumstances as material changes of use:

- a building is used as a dwelling where previously it was not
- a building contains a flat where previously it did not
- a building is used as an hotel or boarding house where previously it was not.
- a building is used as an institution where previously it was not
- a building is used as a public building where previously it was not
- a building no longer comes within the exemptions in Schedule 2 to the Building Regulations where previously it did
- a building which contains at least one dwelling contains a greater or lesser number of dwellings than it did previously
- a building contains a room for residential purposes where previously it did not
- a building which contains at least one room for residential purposes contains a greater or lesser number of such rooms than it did previously
- a building is used as a shop where previously it was not

Parts G1, G3(1) to (3) and G4 to G6 will apply to all the material changes of use mentioned above. This means that whenever such changes occur the building must be brought up to the standards required by Parts G1 and G3 to G6.

Parts G2, G3(4) and Regulation 17K will apply only to material changes of use where a building is used as a dwelling where previously it was not and where a building contains a flat where previously it did not.

Historic buildings

The types of building work covered by this Approved Document may include work on historic buildings. Historic buildings include:

- a. listed buildings
- b. buildings situated in designated conservation areas
- c. buildings which are of architectural or historic interest and which are referred to as a material consideration in a local authority's development plan
- d. buildings of architectural and historical interest within national parks, areas of outstanding or natural beauty and world heritage sites.

Special considerations may apply if the building on which the work is to be carried out has special historic or architectural value, and compliance with the sanitation or hot water safety requirements would unacceptably alter the character or appearance of the building or parts of it.

When undertaking work on or in connection with buildings with special historic or architectural value, the aim should be to improve sanitation and hot water safety where and to the extent that it is possible provided that the work does not prejudice the character of the host building or increase the risk of long-term deterioration to the building's fabric or fittings.

In arriving at a balance between historic building conservation and sanitation or hot water safety requirements, it would be appropriate to take into account the advice of the local authority's conservation officer before work begins. Guidance is also available in the English Heritage publication Building Regulations and Historic Buildings, 2002 (revised 2004), which is available at www.english-heritage.org.uk.

Note: Any building in the schedule of monuments maintained under section 1 of the Ancient Monuments and Archaeological Areas Act 1979 is exempt from all Building Regulations requirements including those in Part G.

Notification of work

In almost all cases of new building work it will be necessary to notify a BCB in advance of any work starting. There are two exceptions to this: where work is carried out under a self-certification scheme listed in Schedule 2A, and where work is listed in Schedule 2B to the Building Regulations as being not notifiable.

Competent person self-certification schemes under Schedule 2A

Under regulation 12(5) of the Building Regulations it is not necessary to notify a BCB in advance of work which is covered by this Approved Document if that work is of a type set out in column 1 of Schedule 2A to the Regulations and is carried out by a person registered with a relevant self-certification (competent persons) scheme as set out in column 2 of that Schedule. In order to join such a scheme a person must demonstrate competence to carry out the type of work the scheme covers, and also the ability to comply with all relevant requirements in the Building Regulations. Details of current schemes including those relating to sanitation, hot water safety and water efficiency can be found in Annex 2 of Approved Document G and from www.communities.gov.uk. These schemes may change from time to time, or schemes may change name, or new schemes may be authorised; the current list on the Communities and Local Government website should always be consulted. Full details of the schemes can be found on the individual scheme websites.

Where work is carried out by a person registered with a competent person scheme, regulation 16A of the Building Regulations and regulation 11A of the Building (Approved Inspectors etc.) Regulations 2000 require that the occupier of the building be given, within 30 days of the completion of the work, a certificate confirming that the work complies with all applicable Building Regulation requirements. There is also a requirement that the BCB be given a notice that this has been done, or a copy of the certificate, again within 30 days of the completion of the work. These certificates and notices are usually made available through the scheme operator.

BCBs are authorised to accept these certificates as evidence of compliance with the requirements of the Building Regulations. However, local authority inspection and enforcement powers remain unaffected, although they are normally used only in response to a complaint that work does not comply.

Work which is not notifiable under Schedule 2B

Schedule 2B to the Building Regulations sets out types of work where there is no requirement to notify a BCB that work is to be carried out. These types of work are mainly of a minor nature where there is no significant risk to health, safety, water efficiency or energy efficiency. Health, safety, water efficiency and energy efficiency requirements continue to apply to these types of work; only the need to notify a BCB has been removed.

Where only non-notifiable work as set out in Schedule 2B is carried out, there is no requirement for a certificate confirming that the work complies with Building Regulation requirements to be given to the occupier or the BCB.

The types of non-notifiable work in Schedule 2B relevant to the sanitation, hot water safety and water efficiency provisions of the Regulations are:

- i. in an existing hot water system, the replacement of any part which is not a combustion appliance, or the addition of an output device or control device. The work will however remain notifiable where commissioning is possible, and will affect the reasonable use of fuel and power. This is most likely to be where water heaters are being provided
- ii. the installation of a stand-alone, self-contained fixed hot water appliance. This is restricted to a single appliance and any associated controls and must not be connected to, or form part of, any other fixed building service. However, if any of the following apply, the work will remain notifiable building work:
 - the service is a combustion appliance
 - any electrical work associated with the installation is notifiable
 - commissioning is possible and would affect the service's energy efficiency, such as that of water heaters
- iii. the replacement of a sanitary convenience with one that uses no more water than the one it replaces, a washbasin, sink, bidet, fixed bath, or a fixed shower bath but only where the work does not include any work to:
 - underground drainage
 - the hot or cold water system or above-ground drainage which could prejudice the health and safety of any person on completion of work
- iv. replacing any part or adding an output or control device to an existing cold water supply
- v. providing a hot water storage system that has a storage vessel with a capacity not exceeding 15 litres provided that any electrical work associated with the installation is also not notifiable.

Schedule 2B also sets out what types of electrical installation work in dwellings is non-notifiable. Full information on this is given in Approved Document P.

Exemptions

Schedule 2 to the Building Regulations sets out a number of classes of buildings which are exempt from all Building Regulations requirements. However, the exemption has been removed in respect of some requirements of Part G where hot or cold water supply systems are shared with other buildings. This is to help ensure that the whole hot or cold water system is safe. In particular:

- i. the requirements of Parts G 1, G3(2) and G3(3) will apply to any greenhouse which receives a

hot or cold water supply from a source shared with or located inside a dwelling

- ii. the requirements of Parts G1, G3(2) and G3(3) will apply to any small detached building falling within Class VI of Schedule 2 and any extension falling within Class VII of Schedule 2 (which includes conservatories under 30m² in area) which receives a hot or cold water supply shared with or located inside any building that is subject to the Regulations.

Please note that the Regulations do not require the provision of hot or cold water systems to such exempt buildings, but if such systems are provided they must meet the minimum hygiene and safety requirements in those Parts.

All other Classes of buildings within Schedule 2 retain their exemption from compliance with Part G.

Materials and workmanship

Building Regulations may be set up for specified purposes including: securing the health, safety, welfare and convenience of persons in or about buildings, protecting and enhancing the environment, facilitating sustainable development, furthering the conservation of fuel and power, preventing crime and preventing the waste, misuse, undue consumption or contamination of water.

Any building work within the meaning of the Building Regulations should, in accordance with regulation 7, be carried out with proper materials and in a workmanlike manner.

You may show that you have complied with regulation 7 in a number of ways. These include the appropriate use of a product bearing CE marking in accordance with the Construction Products Directive (89/106/EEC) as amended by the CE Marking Directive (93/68/EEC)¹ or a product complying with an appropriate technical specification (as defined in those Directives), a British Standard or an alternative national technical specification of any state which is a contracting party to the European Economic Area which in use is equivalent, or a product covered by a national or European certificate issued by a European Technical Approval issuing body, and the conditions of use are in accordance with the terms of the certificate.

You will find further guidance in the Approved document supporting regulation 7 on materials and workmanship.

Supplementary guidance

The Department of Communities and Local Government occasionally issues additional material to aid interpretation of the guidance in Approved Documents. This material may be conveyed in official letters to chief executives of local authorities and Approved Inspectors and/or posted on the websites accessed through: www.communities.gov.uk/planningandbuilding/buildingregulations/.

Technical specifications

Standards and technical approvals are relevant guidance to the extent that they relate to health, safety or water efficiency considerations in the Building Regulations. They may also address other aspects of performance such as serviceability, or aspects that, although they relate to health and safety, are not covered by the Building Regulations.

When an Approved Document makes reference to a named standard, the relevant version of the standard is the one listed at the end of the publication. However, if this version of the standard has been revised or updated by the issuing standards body, the new version may be used as a source of guidance provided that it continues to address the relevant requirements of the Building Regulations. Where it is proposed to work to the new version instead of the version listed at the end of the publication, this should be discussed with the BCB in advance of any work starting.

The appropriate use of a product, which complies with a European Technical Approval as defined in the Construction Products Directive, (89/106/EEC) should meet the relevant requirements.

¹ Implemented by the Construction Products Regulations 1991 (SI 1991/1620), amended by the Construction Products (Amendment) Regulations 1991 (SI 1991/1620).

Independent schemes of certification and accreditation

Much of the guidance throughout this document is given in terms of performance.

Since the performance of a system, product, component or structure is dependent upon satisfactory site installation, testing and maintenance, independent schemes of certification and accreditation of installers and maintenance firms will provide confidence in the appropriate standard of workmanship being provided.

Confidence that the required level of performance can be achieved will be demonstrated by the use of a system, material, product or structure which is provided under the arrangements of a product conformity certification scheme and an accreditation of installer scheme.

Third party accredited product conformity certification schemes not only provide a means of identifying materials and designs of systems, products and structures which have demonstrated that they reach the requisite performance, but additionally provide confidence that the systems, materials, products and structures are actually provided to the same specification or design as that tested or assessed.

Third party accreditation of installers of systems, materials, products and structures provides a means of ensuring that installations have been conducted by knowledgeable contractors to appropriate standards, thereby increasing the reliability of the anticipated performance.

Many certification bodies that approve such schemes are accredited by the United Kingdom Accreditation Service.

BCBs may accept certification of products, components, materials or structures under such schemes as evidence of compliance with the relevant standard. Similarly BCBs may accept the certification of installation or maintenance of products, components, materials and structures under such schemes as evidence of compliance with the relevant standard. Nonetheless a BCB will wish to establish in advance of the work, that any such scheme is adequate for the purpose of the Building Regulations.

Interaction with other legislation

This Approved Document makes reference to other legislation, including those listed below, that may also need to be considered.

Note: All statutory instruments can be accessed at www.opsi.gov.uk.

The Water Supply (Water Quality) Regulations 2000 (SI 2000/3184 as amended), and in Wales **the Water Supply (Water Quality) Regulations 2001** (SI 2001/3911 as amended) are made under the Water Industry Act 1991 and apply to the supply of water by a statutory water undertaker or a licensed water supplier. They make provision for the wholesomeness of water supplied for such domestic purposes as consist in or include cooking, drinking, food preparation or washing; or to premises in which food is produced.

The Water Supply (Water Fittings) Regulations 1999 (SI 1999/1148 as amended) are made under the Water Industry Act 1991 and apply to any water fitting installed or used, or to be installed or used, in premises to which water is or is to be supplied by a water undertaker. They make provision for preventing contamination, waste, misuse, undue consumption and erroneous measurement of water supplied by a statutory water undertaker or licensed water supplier.

The Private Water Supplies Regulations 1991 (SI 1991/2790) are made under the Water Industry Act 1991 and are concerned with the quality of water supplied from private supplies in England and Wales for drinking, washing or cooking or for food production purposes. They make provision for standards of wholesomeness in respect of water from private supplies for drinking, washing or cooking or for food production purposes.

The Workplace (Health, Safety and Welfare) Regulations 1992 (SI 1992/3004 as amended) are made under the Health and Safety at Work etc. Act 1974 and apply to any workplace or part of a workplace. They apply to the common parts of flats and similar **buildings** if people such as cleaners, wardens and caretakers are employed to work in these common parts. They make provision for, amongst other matters, space requirements, cleaning and provision of **sanitary conveniences**.

Food Hygiene (England) Regulations 2006 (SI 2006/14 as amended) and **the Food Hygiene (Wales) Regulations 2006** (SI 2006/31 W5 as amended) are made under European Communities Act 1972 and apply to measures relating to food (including drink) including the primary production of food. The provision of **washbasins and sinks** is relevant to Approved Document G.

Gas Safety (Installation and Use) Regulations (SI 1998/2451) extend to all dangers arising from the transmission, distribution, supply or use of gas conveyed from a gas storage vessel. The installation of gas heated water systems is relevant to Approved Document G.

The Requirement G1

This Approved Document deals with the following Requirement from Part G of Schedule 1 to the Building Regulations 2000 (as amended).

<i>Requirement</i>	<i>Limits on application</i>
<p>Cold water supply</p> <p>G1. (1) There must be a suitable installation for the provision of wholesome water to:</p> <ul style="list-style-type: none">(a) any place where drinking water is drawn off;(b) any washbasin or bidet provided in or adjacent to a room containing a sanitary convenience;(c) any washbasin, bidet, fixed bath and shower in a bathroom; and(d) any sink provided in any area where food is prepared. <p>(2) There must be a suitable installation for the provision of water of suitable quality to any sanitary convenience fitted with a flushing device.</p>	

DRAFT

DRAFT

Guidance

Performance

In the Secretary of State's view Requirement G1(1) will be met if:

- a. the water supplied is wholesome;
- b. the pressure and flow rate is sufficient for the operation of **sanitary appliances** planned in the **building**;
- c. the supply is reliable; and
- d. the installation conveys **wholesome water** to the **sanitary appliances** and locations specified in the Requirement without waste, misuse, undue consumption or contamination of water.

The water will be wholesome if it is provided:

- a. by a statutory water undertaker or a licensed water supplier; or
- b. by a source complying with the Private Water Supplies Regulations 1991 (SI 1991/2790 as amended).

In the Secretary of State's view Requirement G1(2) will be met if:

- a. the water is either wholesome or of suitable quality having regard to the risks to health;
- b. the pressure and flow rate is sufficient for the operation of the **sanitary appliances**;
- c. the supply is reliable; and
- d. the installation conveys water to **sanitary appliances** and locations specified in the Requirement without waste, misuse, undue consumption or contamination of **wholesome water**.

Wholesome water (all buildings)

1.1 Water supplied to the **building** by a statutory water undertaker or a licensed water supplier through an installation complying with the requirements of the Water Supply (Water Fittings) Regulations 1999 (SI 1999/1148 as amended) may be assumed to be **wholesome water**. The requirements in those regulations are set out for ease of reference in Annex 1 to this Approved Document.

1.2 Attention is drawn to the requirements of the Water Supply (Water Fittings) Regulations 1999 (SI 1999/1148 as amended) which make provision for preventing contamination, waste, misuse, undue consumption and erroneous measurement of water supplied by a water undertaker or licensed water supplier.

1.3 Where a **building** is supplied with water from a source other than a water undertaker or licensed water supplier, the water shall be considered to be wholesome if it meets the criteria set out in the Private Water Supplies Regulations 1991 (SI 1991/2790). The requirements in those regulations are set out for ease of reference in Annex 1 to this Approved Document.

Non-wholesome water (all buildings)

1.4 Water treated to the high standards of **wholesome water** is not essential for all of the uses that water is put to in and about **buildings**, e.g. toilet flushing, irrigation. A variety of alternative sources are available for water. These include:

- a. water abstracted from wells, springs, bore-holes or water courses;
- b. **harvested rainwater**;
- c. reclaimed **greywater**; and
- d. reclaimed industrial process water.

1.5 The design of treatment systems for water from **non-wholesome water** sources should incorporate measures to minimise the impact on water quality of:

- a. failure of any components;
- b. failure to undertake any necessary maintenance;
- c. power failure where appropriate; and
- d. any other measures identified in a risk assessment.

1.6 Guidance on the marking of pipework conveying water from non-wholesome sources can be found in the WRAS Information & Guidance Note No. 9-02-05 *Marking and identification of pipework for reclaimed (greywater) systems*.

1.7 Guidance on installing, modifying and maintaining reclaimed water systems can be found in the WRAS Information and Guidance Note No. 9-02-04 *Reclaimed water systems* and in BS 8515:2009 *Rainwater harvesting systems. Code of practice*.

1.8 Information on the technical and economic feasibility of rainwater and **greywater** can be found in MTP (2007) *Rainwater and greywater: technical and economic feasibility*.

1.9 Information on the specification of rainwater and **greywater** systems can be found in MTP (2007) *Rainwater and greywater: a guide for specifiers*.

1.10 Guidelines for rainwater and **greywater** systems, in relation to water quality standards, can be found in MTP (2007) *Rainwater and greywater: review of water quality standards and recommendations for the UK*.

1.11 Water from appropriate non-wholesome sources may be used in dwellings for **sanitary conveniences**, washing machines and irrigation, provided the appropriate risk assessment has been carried out. A **risk assessment** should ensure that the supply is appropriate to the situation in respect of the source of the water and the treatment of it, and not likely to cause waste, misuse, undue consumption or contamination of **wholesome water**.

1.12 Any system/unit used to supply dwellings with water from non-wholesome sources should be subject to a risk assessment by the system designer and manufacturer, and appropriate testing carried out to demonstrate that any risks have been suitably addressed. A risk assessment should include consideration of the effect on water quality of system failure and failure to carry out necessary maintenance.

The Requirement G2 and regulation 17K

This Approved Document deals with the following Requirement from Part G of Schedule 1 and regulation 17K to the Building Regulations 2000 (as amended).

<i>Requirement</i>	<i>Limits on application</i>
<p>Water efficiency</p>	<p>Requirement G2 applies only when a dwelling is—</p> <p>(a) erected; or</p> <p>(b) formed by a material change of use of a building within the meaning of regulation 5(a) or (b)."</p>
<p>G2. Reasonable provision must be made by the installation of fittings and fixed appliances that use water efficiently for the prevention of undue consumption of water.</p> <p>Water efficiency of new dwellings</p> <p>17K.—(1) The potential consumption of wholesome water by persons occupying a dwelling to which this regulation applies must not exceed 125 litres per person per day, calculated in accordance with the methodology set out in the document “The Water Efficiency Calculator for New Dwellings”.</p> <p>(2) This regulation applies to a dwelling which is—</p> <p>(a) erected; or</p> <p>(b) formed by a material change of use of a building within the meaning of regulation 5(a) or (b).”.</p> <p>(10) In regulation 20(1) (supervision of building work otherwise than by local authorities) for “and 20D” substitute “, 20D and 20E”.</p> <p>(11) After regulation 20D (CO₂ emission rate calculations) insert—</p>	
<p>Wholesome water consumption calculation</p>	
<p>20E.—(1) Where regulation 17K applies, the person carrying out the work must give the local authority a notice which specifies the potential consumption of wholesome water per person per day calculated in accordance with the methodology referred to in that regulation in relation to the completed dwelling.</p> <p>(2) The notice shall be given to the local authority not later than five days after the work has been completed.”.</p>	
<p>Building (Approved Inspectors) Regulations 2000</p>	
<p>12E. (1) Where regulation 17K of the Principal Regulations applies to work which is the subject of an initial notice, the person carrying out the work must give the approved inspector a notice which specifies the potential consumption of wholesome water per person per day calculated in relation to the completed dwelling.</p> <p>(2) The notice shall be given to the approved inspector not later than—</p> <p>(a) five days after the work has been completed; or</p> <p>(b) the date on which, in accordance with regulation 18, the initial notice ceases to be in force,</p> <p>whichever is the earlier.</p>	

Guidance

Performance

In the Secretary of State's view Requirement G2 will be met for new dwellings if:

- a. the design of cold and hot water systems (calculated in accordance with the guidance set out in this Approved Document and taking into account the use of any alternative sources of water provided in accordance with G1(2)) is not greater than the standard set by the Secretary of State of 125 litres/head/day of **wholesome water**;
- b. **sanitary appliances** and white goods used in the design calculation undertaken to demonstrate compliance with paragraph (a) are provided and installed in the dwelling taking account of the other provisions in this Approved Document;
- c. any alternative sources of water used in the design calculation undertaken to demonstrate compliance with paragraph (a) are supplied to the dwelling, taking account of other provisions in this Approved Document;
- d. a record of the **sanitary appliances** and white goods used to meet the target and installed in the dwelling is provided along with sufficient other information enabling **buildings** owners or occupiers to maintain the **building** and its services so as to maintain the water efficiency of the **building**.
- e. a record of the alternative **sources of water** used to meet the target and supplied to the dwelling is provided along with sufficient other information enabling **buildings** owners or occupiers to maintain the **building** and its services so as to maintain the water efficiency of the **building**.

In this context, relevant white goods are washing machines and dishwashers.

Where a **building** consists of more than one dwelling (such as a block of flats) it should be designed so that the cold and hot water systems for each individual dwelling should be no greater than the target.

Where it can be demonstrated that a dwelling meets the minimum water efficiency standard in the Code for Sustainable Homes, the dwelling shall be presumed to meet requirement G2.

General

2.1 The water used by **sanitary appliances** and relevant white goods in a new dwelling should be calculated using the manufacturer's declared value for water consumption of each of those appliances and white goods.

2.2 The estimated water consumption of a new dwelling should be calculated in accordance with the methodology set out in the "Water Efficiency Calculator for New Dwellings" (2).

2.3 The estimated consumption of **wholesome water** of a new dwelling should be not more than 125 litres/head/day (l/h/d). This includes a fixed factor of water for outdoor use of 5 l/h/d.

2.4 Where alternative, non-wholesome, sources of water are to be used in the dwelling design, this should be reflected in the estimate of water use.

Notification of water efficiency calculation to the BCB

- Where Regulation 17K applies, Regulation 20E of the Building Regulations (where the BCB is the local authority) and Regulation 12E of the Building (Approved Inspectors etc.) Regulations respectively require that a notice specifying the calculated potential consumption of **wholesome water** per person per day relating to the dwelling as constructed be given to the appropriate **BCB**.
- In most cases, this notice must be given to the **BCB** not later than five days after the completion of the **building work**. However, where the **BCB** is an Approved Inspector and the dwelling is occupied before completion, the notice must be given not later than the day that the initial notice ceases to be in force in consequence of Regulation 18 of the Building (Approved Inspectors etc) Regulations when this is earlier than five days after the completion of the work.
- It is permissible for the notice to be served on the **BCB** electronically provided the **BCB** has stated its willingness to receive the document by those means and it is delivered to the electronic address that the body has specified.
- Local authorities will not be able to give a completion certificate for the building until the notice required under regulation 20E of the Building Regulations has been received. Approved Inspectors are unlikely to be able to give a final certificate until the equivalent notice under Regulation 12E of the Building (Approved Inspectors etc.) Regulations has been received.

The Requirement G3

This Approved Document deals with the following Requirement from Part G of Schedule 1 to the Building Regulations 2000 (as amended).

<i>Requirement</i>	<i>Limits on application</i>
<p>G3. (1) There must be a suitable installation for the provision of heated wholesome water to:</p> <ul style="list-style-type: none"> (a) any washbasin or bidet provided in or adjacent to a room containing a sanitary convenience; (b) any washbasin, bidet, fixed bath and shower in a bathroom; and (c) any sink provided in any area where food is prepared. <p>(2) A hot water system, including any cistern or other vessel that supplies water to or receives expansion water from a hot water system, shall be designed, constructed and installed so as to resist the effects of temperature and pressure that may occur either in normal use or in the event of such malfunctions as may reasonably be anticipated, and must be adequately supported.</p> <p>(3) A hot water system that has a hot water storage vessel shall incorporate precautions to:</p> <ul style="list-style-type: none"> (a) prevent the temperature of the water stored in the vessel at any time exceeding 100°C; and (b) ensure that any discharge from safety devices is safely conveyed to where it is visible but will not cause a danger to persons in or about the building. <p>(4) The hot water supply to any fixed bath must be so designed and installed as to incorporate measures to ensure that the temperature of the water that can be delivered to that bath shall not exceed 48°C.</p>	<p>Requirement G3(3) does not apply to a system which heats or stores water for the purposes only of an industrial process.</p> <p>Note: Some of these systems may be subject to the Pressure Systems Safety Regulations 2000.</p> <p>Requirement G3(4) applies only when a dwelling is—</p> <ul style="list-style-type: none"> (a) erected; (b) formed by a material change of use within the meaning of regulation 5(a) or (b).

DRAFT

Guidance

Performance

In the Secretary of State's view requirement G3(1) will be met if:

- a. the installation conveys hot water to the **sanitary appliances** and locations specified in the requirement without waste, misuse or undue consumption of water; and
- b. the water supplied is **heated wholesome water**.

In the Secretary of State's view requirement G3(2) will be met if all components of the hot water system including any cistern that supplies water to, or receives expansion water from the hot water system continues to safely contain the hot water:

- a. during normal operation of the hot water system;
- b. following failure of any thermostat used to control temperature; and
- c. during operation of any of the safety devices fitted in accordance with paragraph G3(3).

In the Secretary of State's view requirement G3(3) will be met for a **hot water storage system** that has a vented storage vessel if:

- a. the storage vessel has a suitable vent pipe connecting the top of the vessel to a point open to the atmosphere above the level of the water in the cold water storage cistern and over it; and,
- b. in addition to any thermostat, either the heat source, or the storage vessel is fitted with a device that will prevent the temperature of the stored water at any time exceeding 100°C; and
- c. the hot water system has pipework that incorporates a provision for the discharge of hot water from the safety devices to an appropriate place open to the atmosphere where it will cause no danger to persons in or about the **building**.

In the Secretary of State's view requirement G3(3) will be met for a hot water system that has an unvented storage vessel if:

- a. the storage vessel has at least two independent safety devices that prevent the temperature of the stored water at any time exceeding 100°C in addition to any thermostat; and
- b. the hot water system has pipework that incorporates a provision for the discharge to be visible at some point and safely conveys any discharge of hot water from safety devices to an appropriate place open to the atmosphere where it will cause no danger to persons in or about the **building**.

In the Secretary of State's view requirement G3(4) will be met if:

the hot water outlet temperature is appropriate for the appliance being served, and any device to fix the maximum temperature that can be supplied at the outlet can not be easily altered by **building users**.

General

3.1 The delivered hot water can be considered as **heated wholesome water** where:

- a. the cold water supply to the hot water system is wholesome; and
- b. the installation complies with the requirements of the Water Supply (Water Fittings) Regulations 1999 (SI 1999/1148 as amended).

3.2 The Water Supply (Water Fittings) Regulations make provision for preventing contamination, waste, misuse, undue consumption and erroneous measurement of water supplied by a water undertaker or licensed water supplier. Guidance on the application of the Water Supply (Water Fittings) Regulations can be found in the Water Regulations Guide published by the Water Regulations Advisory Scheme.

3.3 Attention is also drawn to the requirements of the Gas Safety (Installation and Use) Regulations for all gas installation work.

3.4 Electrical work associated with hot water systems should be carried out in accordance with BS7671:2008 *Requirements for electrical installations (IEE Wiring Regulations 17th Edition)*.

3.5 For installations in dwellings and associated **buildings**, attention is drawn to Building Regulations 2000 Schedule 1 Part P (Electrical safety – Dwellings) and to Approved Document P.

3.6 For workplaces, attention is also drawn to the HSC publication *Legionnaires' Disease: Control of Legionella Bacteria in Water Systems. Approved code of practice and guidance*. L8, Health and Safety Commission 2000. ISBN 0 7176 1772 6.

3.7 Pipework should be designed and installed in such a way as to minimise the transfer time between the **hot water storage system** and hot water outlets.

3.8 The safety requirements for hot water systems used solely for supplying water for industrial processes is contained in the Pressure Systems Safety Regulations 2000 and further guidance is available in *Safety of pressure systems. Pressure Systems Safety Regulations 2000. Approved Code of Practice L122 HSE Books 2000*. ISBN 0 7176 1767 X.

Provision of hot water supply

3.9 The requirement G3 only requires the provision of a hot water supply to:

- a. any washbasin provided in association with a sanitary convenience in accordance with G4(2),
- b. any washbasin, bidet, fixed bath or shower in a bathroom in a dwelling or provided for rooms for residential purposes, provided in accordance with G5
- c. any **sink** in a food preparation area, provided in accordance with G6.

There is no requirement under the Building Regulations to provide hot water to other washing facilities, but there may be such requirements under other legislation (see paragraphs 4.3, 4.4 and 6.3).

Design and installation of directly or indirectly heated hot water storage systems

General

3.10 Hot water storage systems should be designed and installed in accordance with BS 6700:2006 *Specification for design, installation, testing and maintenance of services supplying water for domestic use within buildings and their curtilages* or BS EN 12897:2006 *Water supply. Specification for indirectly heated unvented (closed) storage water heaters*.

3.11 Hot water storage vessels should conform to BS 853-1:1996 *Specification for vessels for use in heating systems. Calorifiers and storage vessels for central heating and hot water supply*, BS 1566-1:2002 *Copper indirect cylinders for domestic purposes. Open vented copper cylinders. Requirements and test methods*, or BS 3198:1981 *Specification for copper hot water storage combination units for domestic purposes*, as appropriate.

Vented hot water storage systems

3.12 Vented **hot water storage systems** should incorporate a vent pipe of an adequate size, but not less than 19mm internal diameter, connecting the top of the vessel to a point open to the atmosphere above and over the level of the water in the cold water storage cistern.

3.13 In addition to the vent pipe referred to in 3.12 and any thermostat provided to control the temperature of the stored water to a desired temperature, vented **hot water storage systems** should incorporate:

- a. either
 - i. for all direct heat sources, a non-self-resetting energy cut-out to disconnect the supply of heat to the storage vessel in the event of the storage system overheating; or,

- ii. for all indirect heat sources, an overheat cut-out to disconnect the supply of heat to the storage vessel in the event of the stored water overheating so that the temperature of the stored water does not exceed 100°C; and

- b. a **temperature relief valve** or a **combined temperature and pressure relief valve** to safely discharge the water in the event of significant over heating.

3.14 Vent pipes should discharge over a cold water storage cistern conforming to BS 417-2:1987 *Specification for galvanized low carbon steel cisterns, cistern lids, tanks and cylinders. Metric units*; or BS 4213:2004 *Cisterns for domestic use. Cold water storage and combined feed and expansion (thermoplastic) cisterns up to 500 litres. Specification*; as appropriate.

3.15 The cold water storage cistern into which the vent pipe discharges should be supported on a flat, level, rigid platform which is capable of safely withstanding the weight of the cistern when filled with water to the rim and fully supporting the bottom of the cistern over the whole of its area. The platform should extend a minimum of 150mm in all directions beyond the edge of the maximum dimensions of the cistern.

Note: Where an existing metal cistern is replaced, or a plastic cistern is replaced by one with larger dimensions, the existing support should be upgraded, as necessary, with one in accordance with paragraph 3.15.

3.16 The cistern should be accessible for maintenance, cleaning and replacement.

Unvented hot water storage systems – all systems

3.17 In addition to any thermostat provided to control the temperature of the stored water to a desired temperature, unvented **hot water storage systems** should incorporate a minimum of two temperature activated safety devices operating independently in series, normally:

- a. a non-self-resetting energy cut-out to disconnect the supply of heat to the storage vessel in the event of the storage system overheating; and
- b. a **temperature relief valve** or a **combined temperature and pressure relief valve** to safely discharge the water in the event of serious over heating.

Note: See 3.33 for suitability of devices for **primary thermal stores**.

3.18 Water heaters with a capacity of 15 litres or less that have appropriate safety devices for temperature and pressure will generally satisfy the requirement set out in G3(3).

Unvented hot water storage systems – systems up to 500 litres capacity and 45kW power input

3.19 Paragraphs 3.20 to 3.23 are in addition to the provisions of 3.17 above.

3.20 If an indirect supply of heat to an unvented **hot water storage system** incorporates a boiler, the energy cut-out may be on the boiler.

3.21 Any unvented **hot water storage system** up to 500 litres and less than 45kW should be in the form of a proprietary **hot water storage system unit** or package. The package and components should be appropriate to the circumstances in which they are used and should satisfy an appropriate standard that will ensure the requirements of regulation G3(2) and G3(3) will be met (e.g. BS EN 12897:2006 *Water Supply. Specification for indirectly heated unvented (closed) hot water storage systems* or BS 6700:2006 *Design, installation, testing and maintenance of services supplying water for domestic use within buildings and their curtilages*).

3.22 Any unvented **hot water storage system unit** or package should be indelibly marked with the following information:

- a. the manufacturer’s name and contact details;
- b. a model reference;
- c. the rated storage capacity of the storage water heater;
- d. the operating pressure of the system and the operating pressure of the expansion valve;
- e. the operating temperature of the **temperature relief valve** or the operating temperature and pressure of the **combined temperature and pressure relief valve**; and
- f. the maximum primary circuit pressure and flow temperature of indirect **hot water storage system units** or **packages**.

3.23 In addition, the following warning should be indelibly marked on the **hot water storage system unit** or package so that it is visible after installation:

WARNING TO USER

- a. Do not remove or adjust any component part of this unvented water heater; contact the installer.
- b. If this unvented water heater develops a fault, such as a flow of hot water from the discharge pipe, switch the heater off and contact the installer.

WARNING TO INSTALLER

- a. This installation is subject to the Building Regulations.
- b. Use only appropriate components for installation or maintenance.

Installed by:

Name

Address

Tel. No.

Completion date

Unvented hot water storage systems – systems over 500 litres capacity or over 45kW power input

3.24 Paragraph 3.25 and 3.26 are in addition to the provisions of 3.17 above.

3.25 Systems over 500 litres capacity will generally be bespoke designs for specific projects and as such are inappropriate for approval by a third party accredited product conformity certification scheme. Where this is the case, the unvented **hot water storage system** should be designed to the safety requirements in 3.17 by an appropriately qualified engineer.

3.26 Any unvented **hot water storage system** having a power input of more than 45kW, but a capacity of 500 litres or less should be in the form of a proprietary **hot water storage system unit** or package. The package and components should be appropriate to the circumstances in which they are used and should satisfy an appropriate standard that will ensure the requirement of regulation G3(2) and G3(3) will be met (e.g. BS EN 12897:2006 *Water Supply. Specification for indirectly heated unvented (closed) hot water storage systems* or BS 6700:2006 *Design, installation, testing and maintenance of services supplying water for domestic use within buildings and their curtilages*).

Safety devices

Non-self-resetting energy cut-outs

3.27 Non-self-resetting energy cut-outs may only be used where they would have the effect of instantly disconnecting the supply of energy to the storage vessel.

3.28 Non-self-resetting energy cut-outs should conform to:

- a. BS EN 60335-2-73:2003 *Specification for safety of household and similar electrical appliances. Particular requirements. Fixed immersion heaters* and BS EN 60730-2-9:2002 *Automatic electrical controls for household and similar use. Particular requirements for temperature sensing control*; or
- b. BS EN 257:1992 *Mechanical thermostats for gas-burning appliances*.

3.29 Where a non self-resetting energy cut-out operates indirectly on another device (see paragraph 3.17) to interrupt the supply of heat (e.g. it is wired up to a motorised valve or some other suitable device to shut off the flow to the primary heater), the energy cut-out should comply with the relevant European Standard (see paragraph 3.28) or the supplier or installer should be able to demonstrate that the device has equivalent performance to that set out in relevant standards.

3.30 Where an electrical device is connected to the energy cut-out, such as a relay or motorised valve, the device should operate to interrupt the

supply of energy if the electrical power supply is disconnected.

3.31 Where there is more than one energy cut-out (see paragraph 3.33), each non-self-resetting energy cut-out should be independent (e.g. each should have a separate motorised valve and a separate temperature sensor).

3.32 Where a system has more than one heat source, each heat source should have a separate non self-resetting energy cut-out.

Temperature and pressure relief valves

3.33 Temperature relief valves and **combined temperature and pressure relief valves** should not be used in systems which have no provision to automatically replenish the stored water (e.g. unvented primary thermal storage vessels). In such cases there should be a second non-self-resetting energy cut-out independent of the one provided in accordance with paragraph 3.17(a).

3.34 Temperature relief valves should conform to BS 6283-2:1991 *Safety and control devices for use in hot water systems. Specifications for temperature relief valves for pressures from 1 bar to 10 bar*.

3.35 **Combined temperature and pressure relief valves** should conform to BS EN 1490:2000 *Building valves. Combined temperature and pressure relief valves. Tests and Requirements*.

3.36 In both units and packages, **temperature relief valves**, specified in paragraph 3.17, should be located directly on the storage vessel. There should be an appropriate number of valve(s) that comply with BS 6283 *Safety and control devices for use in hot water systems* Part 2 or 3 or equivalent to give a combined discharge rating at least equal to the power unit, or equally suitable **temperature relief valves** marked with the set temperature in °C and the discharge rating marked in kW, measured in accordance with Appendix F of BS 6283-2 or Appendix G of BS 6283-3 or equivalent.

3.37 The **temperature relief valve(s)** or **combined temperature and pressure relief valve(s)** specified in paragraph 3.17 should be located directly on the storage vessel, such that the stored water does not exceed 100°C.

3.38 In **hot water storage system units** and packages, the **temperature relief valve(s)** specified in paragraph 3.17 should be:

- a. factory fitted and should not be disconnected other than for replacement; and
- b. not relocated in any other device or fitting installed.

3.39 The safety and performance of an unvented system is dependent on choice of an appropriate system for the location and correct installation of the system. Building owners and occupiers should therefore take care to choose installers who have the necessary skills to carry

out this work. For example, these skills can be demonstrated by registration with a competent person scheme for this type of work or by the holding of a current registered operative skills certification card for unvented hot water systems.

3.40 The installation of an unvented system is notifiable building work which must be notified to the **BCB** before work commences. The **BCB** may then check to make sure the work is safe and meets current energy efficient requirements.

3.41 However, if the installer is registered with a competent person scheme for the installation of unvented hot water systems it will not be necessary for the work to be notified in advance to the BCB. Installers registered with such schemes will self-certify that the work complies with all relevant requirements in the Building Regulations and the building owner/occupier will be given a building regulations certificate of compliance which is usually issued by the competent person scheme operator.

Electric water heating

3.42 Electric fixed immersion heaters should comply with the provisions of BS EN 60335-2-73:2003 *Household and similar electrical appliances. Safety. Particular requirements for fixed immersion heaters*.

3.43 Electric instantaneous water heaters should comply with the provisions of BS EN 60335-2-35:2002 *Specification for safety of household and similar electrical appliances*.

3.44 Electric storage water heaters should comply with the provisions of BS EN 60335-2-21:2003 *Household and similar electrical appliances. Safety. Particular requirements for storage water heaters*.

Solar water heating

3.45 Factory-made solar water heating systems should comply with the provisions of BS EN 12976-1:2006 *Thermal solar systems and components. Factory made systems. General requirement*.

3.46 Other solar water heating systems should comply with the provisions of prEN/TS 12977-1:2008 *Thermal solar systems and components. Custom built systems. General requirements for solar water heaters and combi systems*, or BS 5918:1989 *British Standard Code of Practice for Solar heating systems for domestic hot water* as appropriate. Further guidance is available in *CIBSE Guide G, Public Health Engineering and CIBSE technical guide Solar Heating Design and Installation*.

3.47 Where solar water heating systems are used, an additional heat source should be available.

Note: The additional heat source should be used, when necessary, to maintain the water temperature to restrict microbial growth.

3.48 Some solar hot water systems operate at elevated temperatures and pressures, and so all components should be rated to the appropriate temperatures and pressures.

Discharge pipes from safety devices

Discharge pipe D1

3.49 Each of the **temperature relief valves** or **combined temperature and pressure relief valves** specified in 3.13 or 3.17 should discharge either directly or by way of a manifold via a short length of metal pipe (D1) to a **tundish**.

3.50 The diameter of discharge pipe (D1) should be not less than the nominal outlet size of the **temperature relief valve**.

3.51 Where a manifold is used it should be sized to accept and discharge the total discharge from the discharge pipes connected to it.

3.52 Where valves other than the **temperature and pressure relief valve** from a single unvented hot water system discharge by way of the same manifold that is used by the safety devices, the manifold should be factory fitted as part of the **hot water storage system unit** or package.

Tundish

3.53 The **tundish** should be vertical, located in the same space as the unvented **hot water storage system** and be fitted as close as possible to, and lower than, the valve, with no more than 600mm of pipe between the valve outlet and the **tundish** (see Diagram 1).

Note: To comply with the Water Supply (Water Fittings) Regulations, the **tundish** should incorporate a suitable air gap.

3.54 Any discharge should be visible at the **tundish**. In addition, where discharges from safety devices may not be apparent, e.g. in dwellings occupied by people with impaired vision or mobility, consideration should be given to the installation of a suitable safety device to warn when discharge takes place, e.g. electronically operated.

Discharge pipe D2

3.55 The discharge pipe (D2) from the **tundish** should:

- have a vertical section of pipe at least 300mm long below the **tundish** before any elbows or bends in the pipework (see Diagram 1); and
- be installed with a continuous fall thereafter of at least 1 in 200.

3.56 The discharge pipe (D2) should be made of:

- metal; or
- other material that has been demonstrated to be capable of safely withstanding temperatures of the water discharged and is clearly and permanently marked to identify

the product and performance standard (e.g. as specified in the relevant part of BS 7291).

3.57 The discharge pipe D2 should be at least one pipe size larger than the nominal outlet size of the safety device unless its total equivalent hydraulic resistance exceeds that of a straight pipe 9m long, i.e. for discharge pipes between 9m and 18m the equivalent resistance length should be at least two sizes larger than the nominal outlet size of the safety device; between 18 and 27m at least 3 sizes larger, and so on; bends must be taken into account in calculating the flow resistance. See Diagram 1, Table 1 and the worked example.

Note: An alternative approach for sizing discharge pipes would be to follow Annex D, section D.2 of BS 6700:2006 *Specification for design, installation, testing and maintenance of services supplying water for domestic use within buildings and their curtilages*.

Diagram 1 Typical discharge pipe arrangement

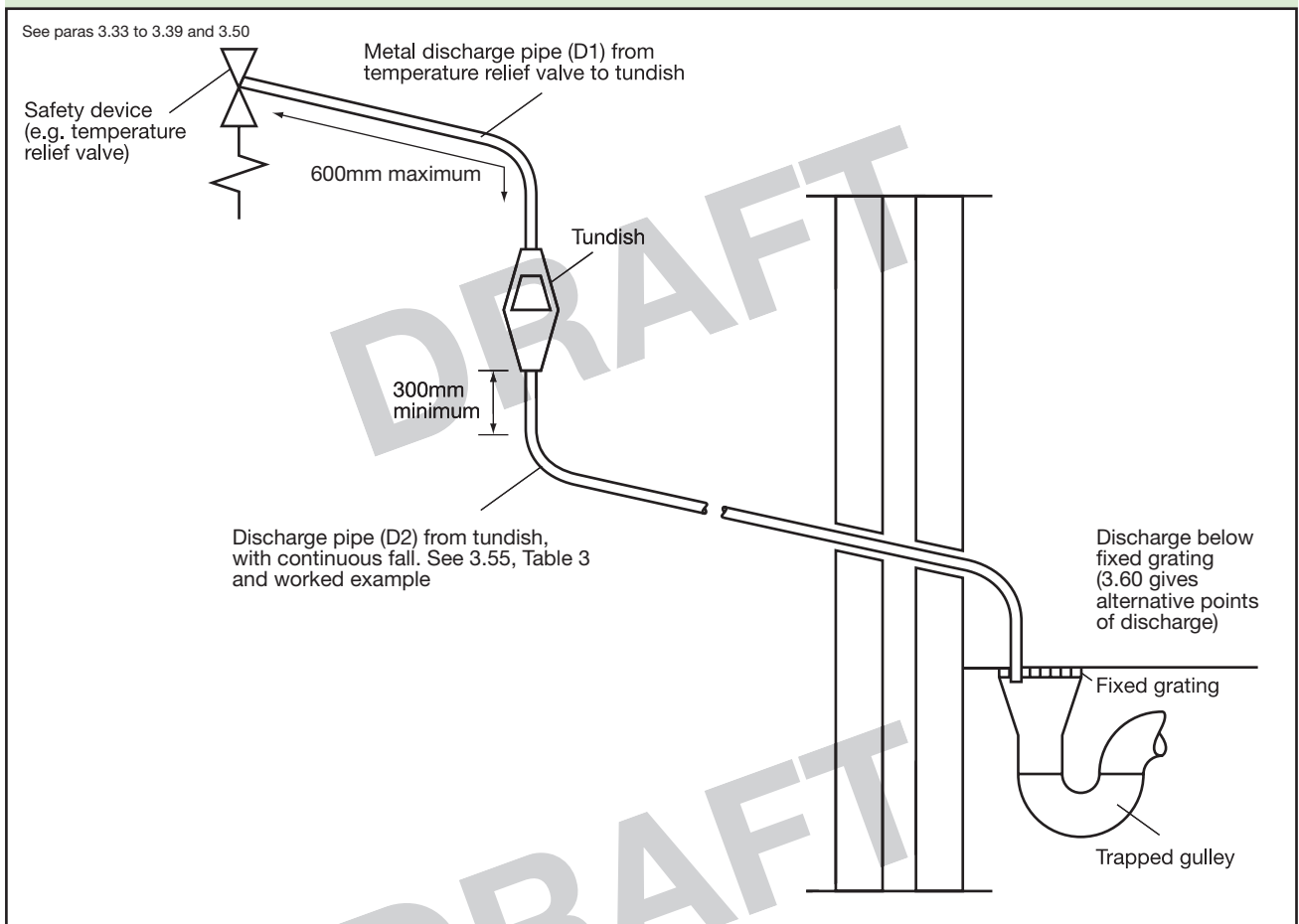

Table 1 Sizing of copper discharge pipe 'D2' for common temperature relief valve outlet sizes

Valve outlet size	Minimum size of discharge pipe D1*	Minimum size of discharge pipe D2* from tundish	Maximum resistance allowed, expressed as a length of straight pipe (i.e. no elbows or bends)	Resistance created by each elbow or bend
G½	15mm	22mm 28mm 35mm	Up to 9m Up to 18m Up to 27m	0.8m 1.0m 1.4m
G¾	22mm	28mm 35mm 42mm	Up to 9m Up to 18m Up to 27m	1.0m 1.4m 1.7m
G1	28mm	35mm 42mm 54mm	Up to 9m Up to 18m Up to 27m	1.4m 1.7m 2.3m

*see 3.49 and 3.56 and Diagram 1

Note: The above table is based on copper tube. Plastic pipes may be of different bore and resistance.

Sizes and maximum lengths of plastic should be calculated using data prepared for the type of pipe being used.

Worked example:

The example below is for a G½ **temperature relief valve** with a discharge pipe (D2) having 4 No. 22mm elbows and length of 7m from the **tundish** to the point of discharge.

From Table 1:

Maximum resistance allowed for a straight length of 22mm copper discharge pipe (D2) from a G½ **temperature relief valve** is: 9.0m

Subtract the resistance for 4 No. 22mm elbows at 0.8m each = 3.2m

Therefore the maximum permitted length equates to 5.8m which, is less than the actual length of 7m therefore calculate the next largest size.

Maximum resistance allowed for a straight length of 28mm copper discharge pipe (D2) from a G½ **temperature relief valve** is: 18m

Subtract the resistance for 4 No. 28mm elbows at 1.0m each = 4m

Therefore the maximum permitted length equates to: 14m

As the actual length is 7m, a 28mm (D2) copper pipe will be satisfactory.

3.58 Where a single common discharge pipe serves more than one system, it should be at least one pipe size larger than the largest individual discharge pipe (D2) to be connected.

3.59 The discharge pipe should not be connected to a soil discharge stack unless it can be demonstrated that the soil discharge stack is capable of safely withstanding temperatures of the water discharged, in which case, it should:

- contain a mechanical seal, not incorporating a water trap, which allows water into the branch pipe without allowing foul air from the drain to be ventilated through the **tundish**;
- be a separate branch pipe with no **sanitary appliances** connected to it;
- if plastic pipes are used as branch pipes carrying discharge from a safety device they should be either polybutalene (PB) to Class S of BS 7291-2:2006 or cross linked polyethylene (PE-X) to Class S of BS 7291-3:2006; and
- be continuously marked with a warning that no **sanitary appliances** should be connected to the pipe.

Note:

- Plastic pipes should be joined and assembled with fittings appropriate to the circumstances in which they are used as set out in BS EN ISO 1043-1.

- Where pipes cannot be connected to the stack it may be possible to route a dedicated pipe alongside or in close proximity to the discharge stack

Termination of discharge pipe

3.60 The discharge pipe (D2) from the **tundish** should terminate in a safe place where there is no risk to persons in the vicinity of the discharge.

3.61 Examples of acceptable discharge arrangements are:

- to a trapped gully with the end of the pipe below a fixed grating and above the water seal;
- downward discharges at low level; i.e. up to 100mm above external surfaces such as car parks, hard standings, grassed areas etc. are acceptable providing that a wire cage or similar guard is positioned to prevent contact, whilst maintaining visibility; and,
- discharges at high level: e.g. into a metal hopper and metal downpipe with the end of the discharge pipe clearly visible or onto a roof capable of withstanding high temperature discharges of water and 3 m from any plastic guttering system that would collect such discharges.

3.62 The discharge would consist of high temperature water and steam. Asphalt, roofing felt and non-metallic rainwater goods may be damaged by such discharges.

Prevention of excessive temperatures

3.63 Where the operating temperature of **domestic hot water** in the storage vessel in a dwelling is capable of exceeding 80°C under normal operating conditions (a situation that may occur in vessels used as heat stores and those connected to solar heat collectors or solid fuel boilers that do not have intervening controls between the boiler and the vessel containing the hot water) the outlet from the storage vessel should be fitted with a device, such as an inline hot water supply tempering valve in accordance with EN15092, to ensure that the temperature supplied to the **domestic hot water** distribution system does not exceed 60°C.

Prevention of scalding

3.64 The hot water supply temperature to a bath should be limited to a maximum of 48°C by use of a in-line blending valve or other appropriate temperature control device, with a maximum temperature stop and a suitable arrangement of pipework.

3.65 The acceptability of in-line blending valves can be demonstrated by compliance with the relevant European Standard to demonstrate that the maximum temperature of 48°C cannot be exceeded in operation and that the product will fail-safe (i.e. not discharge water above the maximum temperature). Such valves should not be easily altered by **building** users. (BS EN 1111:1999 *Sanitary tapware. Thermostatic mixing valves (PN 10). General technical specification* or BS EN 1287:1999 *Sanitary tapware. Low pressure thermostatic mixing valves. General technical specifications*.)

3.66 In-line blending valves and composite thermostatic mixing valves should be compatible with the sources of hot and cold water that serve them.

3.67 The length of supply pipes between blending valves and final outlets should be kept to a minimum in order to prevent the colonisation of waterborne pathogens. If intermittent use of the bath is anticipated, provisions should be made for high temperature flushing to allow for pasteurisation of the pipes and outlet fittings. Such events should be operated in such a manner as to prevent inadvertent use.

Notes:

- 1 Further guidance on the use of in-line blending valves can be found in BRE Information paper IP14/03 *Preventing hot water scalding in bathrooms: using TMVs*
2. In some **buildings**, e.g. care homes, in-line blending valves would need to meet the additional performance standards set out in *NHS Estates Model specification D 08*

Installation

3.68 Good workmanship is essential. Workmanship should be in accordance with BS 8000-15:1990 *Workmanship on Building Sites Code of practice for hot and cold water services (domestic scale)*.

Commissioning of fixed building services

3.69 Water heaters require the input of energy to raise the temperature of water. It is therefore necessary to ensure their efficiency by proper installation and commissioning in the same way as any product or installation that uses energy.

3.70 Fixed **building** services should be commissioned by testing and adjusting as necessary to ensure that they use no more fuel and power than is reasonable in the circumstances. Fixed **building** services includes controls in its meaning. Hot water systems are a fixed **building** service that may require commissioning.

3.71 Commissioning means the advancement of these systems from the state of static completion to working order to achieving compliance with Part L, without prejudice to the need to comply with health and safety requirements. For each system it includes setting-to-work, regulation (that is testing and adjusting repetitively) to achieve the specified performance, the calibration, setting up and testing of the associated automatic control systems, and recording of systems and the performance test results that have been accepted as satisfactory.

3.72 Not all fixed **building** services will need to be commissioned. For example, with some systems it is not possible as the only controls are 'on' and 'off' settings. In other cases commissioning would be possible but in the specific circumstances would have no effect on energy use.

3.73 Where commissioning is carried out it must be done in accordance with a procedure approved by the Secretary of State. For new and existing dwellings the approved procedure for hot water systems is set out in the *Domestic Heating Compliance Guide*; for **buildings** other than dwellings in *CIBSE Commissioning Code M*.

3.74 Commissioning must be carried out in such a way as not to prejudice compliance with any applicable health and safety requirements.

3.75 Commissioning is often carried out by the person who installs the system. Sometimes it may be carried out by a subcontractor or by a specialist firm. It is important that whoever carries it out follows the relevant approved procedure in doing so.

Notice of completion of commissioning

3.76 The Building Regulations (Regulation 20C(2)) and the Building (Approved Inspectors etc.) Regulations (Regulation 12C(2)) require that the person carrying out the work shall give a notice to the relevant BCB that commissioning has been carried out according to a procedure approved by the Secretary of State, unless testing and adjustment is not possible, or would not affect the energy efficiency of the fixed **building** service.

3.77 Where the work is carried out in accordance with a **building** notice, or full plans, or an initial notice or amendment notice, the notice of commissioning should be given not more than 5 days after the completion of the commissioning work. In other cases, for example where work is carried out by a person registered with a competent person scheme, it must be given not more than 30 days after the completion of work.

3.78 Where the installation of fixed building services which require commissioning is carried out by a person registered with a competent person scheme the notice of commissioning will be given by that person.

3.79 Until the BCB receives notice of commissioning it is unlikely to be satisfied that Part G has been complied with and consequently is unlikely to be able to give a completion/final certificate.

The Requirement G4

This Approved Document deals with the following Requirement from Part G of Schedule 1 to the Building Regulations 2000 (as amended).

<i>Requirement</i>	<i>Limits on application</i>
Sanitary conveniences and washing facilities	
<p>G4 (1) Adequate and suitable sanitary conveniences must be provided in rooms provided to accommodate for that purpose or in bathrooms.</p>	
<p>(2) Adequate hand washing facilities must be provided in:</p>	
<p>(a) rooms containing sanitary conveniences; or</p>	
<p>(b) rooms or spaces adjacent to rooms containing sanitary conveniences.</p>	
<p>(3) Any room containing a sanitary convenience, a bidet, or any facility for washing hands provided in accordance with paragraph (2)(b), must be separated from any kitchen or any area where food is prepared.</p>	

DRAFT

DRAFT

Guidance

Performance

In the Secretary of State's view Requirement G4 will be met if:

- Sanitary conveniences of the appropriate type for the sex and age of the persons using the **building** are provided in sufficient numbers, taking into account the nature of the **building**; and
- hand washing facilities are provided in, or adjacent to, rooms containing **sanitary conveniences** and are sited, designed and installed so as not to be prejudicial to health.

General

4.1 Attention is also drawn to the requirements for accessible **sanitary conveniences** and hand washing facilities of Part M of Schedule 1 to the Building Regulations 2000 (Access to and use of buildings) and to Approved Document M and to the Regulators' performance specification made under the Water Supply (Water Fittings) Regulations 1999 (SI 1999/1148 as amended) for WC suites.

4.2 Requirement for ventilation is in Part F Ventilation of Schedule 1 to the Building Regulations 2000. Guidance on ventilation of **sanitary accommodation** is given in Approved Document F.

4.3 The number, type and siting of **sanitary conveniences**, including separate provision for men and women, for staff in workplaces are also subject to the Workplace (Health, Safety and Welfare) Regulations 1992. Attention is drawn to the Approved Code of Practice issued with respect to those Regulations.

4.4 Further guidance on washbasins associated with **sanitary conveniences** may be found in the Food Standards Agency's Code of Practice *Food hygiene – a guide for businesses*.

4.5 Guidance on the selection, installation and maintenance of **sanitary appliances** including composting toilets may be found in BS 6465-3:2006 *Sanitary installations. Code of practice for the selection, installation and maintenance of sanitary and associated appliances*.

4.6 Where hot and cold taps are provided on a **sanitary appliance**, the hot tap should be on the left.

Scale of provision and layout in dwellings

4.7 Any dwelling (house or flat) should have at least one **sanitary convenience** and associated hand washing facility. This will include a **WC** provided in accordance with Part M of Schedule 1 to the Building Regulations 2000 (Access to facilities and buildings) and with Approved Document M.

Note: Part M requires that a **sanitary convenience** should be located in the principal/entrance storey of a dwelling.

4.8 Where additional **sanitary conveniences** are provided, each should have an associated hand washing facility.

4.9 To allow for basic hygiene, hand washing facilities should be located in:

- the room containing the **sanitary convenience**; or
- an adjacent room or place that provides the sole means of access to the room containing the **sanitary convenience** (provided that it is not used for the **preparation of food**).

4.10 A place containing a **sanitary convenience** and/or associated hand washing facilities should be separated by a door from any place used for the **preparation of food** (including a **kitchen**) (see Diagrams 2 and 3).

Note: In dwellings, a room containing both a **sanitary convenience** and a basin for hand washing does not need a separation lobby between this room and a **kitchen** or food preparation area (Diagram 2). The layout for a room containing a **sanitary convenience** only should be such that the room or space containing its associated hand washing facilities is accessed before entry to a food preparation area, and is separated from that area by a door (Diagram 3).

4.11 Guidance on the provision of activity space around **sanitary appliances** is given in BS 6465-2:1996 *Sanitary installations. Code of practice for space requirements for sanitary appliances*.

Diagram 2 Separation between hand washbasin/WC and food preparation area – single room

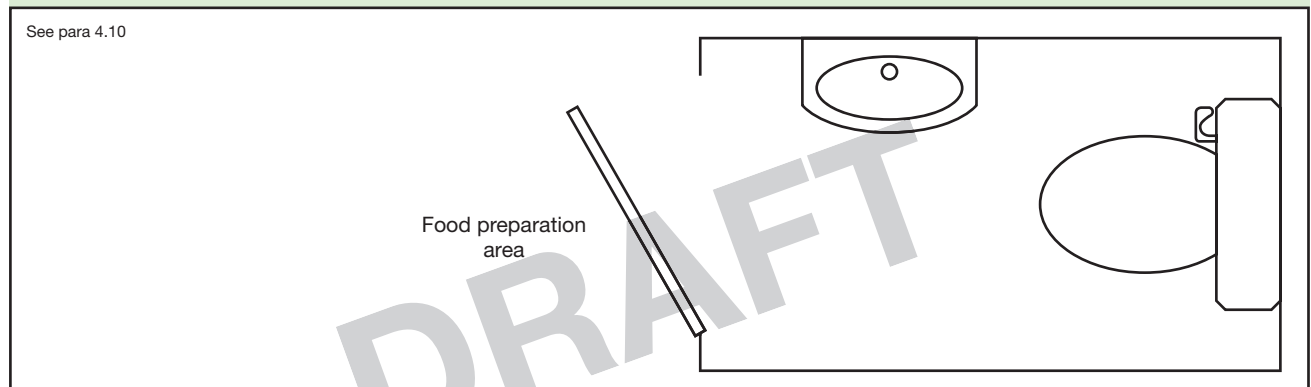
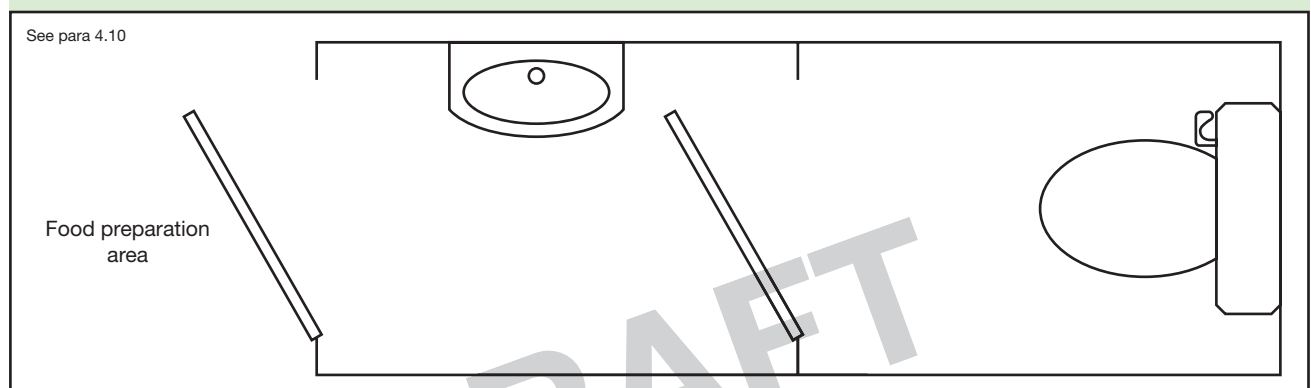

Diagram 3 Separation between hand washbasin/WC and food preparation area – two rooms



Scale of provision and layout in buildings other than dwellings

4.12 The minimum number of **sanitary conveniences** in **buildings** other than dwellings should be in accordance with the Approved Code of Practice (ACOP) for Workplaces that supports the Workplace (Health, Safety and Welfare) Regulations 1992.

4.13 Part M of Schedule 1 to the Building Regulations 2000 sets out requirements relating to access to and use of buildings. Approved Document M provides guidance on the provision of suitable **sanitary accommodation**. Such accommodation may form part of the total number of **sanitary conveniences** provided within a **building**.

4.14 Further guidance on the provision of **sanitary conveniences** that may need to be provided for the **building** types not set out in paragraph 4.12 above, or in those workplaces where the applicant wishes to provide more than the minimum recommended in the Approved Code of Practice referred to in 4.12, can be found in BS 6465-2:2006 *Sanitary installations. Code of practice for the design of sanitary facilities and scales of provision of sanitary and associated appliances*.

4.15 A **sanitary convenience** may be provided in:

- a self-contained room which also contains hand washing facilities;
- in a cubicle with shared hand washing facilities located in a room containing a number of cubicles; or
- in a self-contained room with hand washing facilities provided in an adjacent room.

4.16 Urinals, WC cubicles and hand washing facilities may be in the same room.

4.17 A place containing a **sanitary convenience** and/or associated hand washing facilities should be separated by a door from any place used for the **preparation of food** (including a **kitchen**).

Note: For workplaces, the Workplace (Health, Safety and Welfare) Regulations 1992 apply to the separation of a place containing a **sanitary convenience** and/or associated hand washing facilities and a workplace.

4.18 Guidance on the provision of activity space around **sanitary appliances** is given in BS 6465-2:1996 *Sanitary installations. Code of practice for space requirements for sanitary appliances*.

Chemical and composting toilets

4.19 Chemical toilets or composting toilets may be used where:

- a. suitable arrangements can be made for the disposal of the waste either on or off the site; and
- b. the waste can be removed from the premises without carrying it through any living space or food preparation areas (including a **kitchen**); and
- c. no part of the installation would be installed in any places where it might be rendered ineffective by the entry of flood water.

4.20 There are currently no British or European standards for composting toilets. Appropriate guidance can be found in ANSI/NSF 41-1999 *Non-liquid saturated treatment system*.

4.21 Composting toilets should not be connected to an energy source other than for purposes of ventilation or sustaining the composting process.

Discharges to drains

Note: See Approved Document for requirement H1 *Sanitary pipework and drainage* for guidance on provision for traps, branch discharge pipes, discharge stacks and foul drains.

4.22 Any **WC** fitted with flushing apparatus should discharge to an adequate system of drainage.

4.23 A **urinal** fitted with flushing apparatus should discharge through a grating, a trap or mechanical seal and a branch pipe to a discharge stack or a drain.

4.24 A **WC** fitted with a macerator and pump may be connected to a small bore drainage system discharging to a discharge stack if:

- a. there is also access to a **WC** discharging directly to a gravity system; and
- b. the macerator and pump meets the requirements of BS EN 12050-2:2001 *Wastewater lifting plants for buildings and sites. Principles of construction and testing. Lifting plants for faecal-free wastewater*.

Note: Where **greywater** recycling is used, lower overall flows are to be expected and this should be taken into account in drain design. This is particularly relevant at the head of the drain where only one **building** is connected to the drain.

The Requirement G5

This Approved Document deals with the following requirement from Part G of Schedule 1 to the Building Regulations 2000 (as amended).

<i>Requirement</i>	<i>Limits on application</i>
Bathrooms G5 A bathroom must be provided containing a wash basin and either a fixed bath or a shower.	Requirement G5 applies only to dwellings and to buildings containing one or more rooms for residential purposes.

DRAFT

DRAFT

Guidance

Performance

In the Secretary of State's view Requirement G5 will be met if a bathroom is provided containing a fixed bath or shower, and a washbasin.

General

5.1 The Water Supply (Water Fittings) Regulations 1999 make provisions for appropriate backflow protection on taps including mixer fittings and hose connections.

5.2 Requirements for ventilation are in Part F of Schedule 1 to the Building Regulations 2000 (Ventilation). Guidance on ventilation of **sanitary accommodation** is given in Approved Document F.

5.3 Requirements for electrical safety are given in Part P of Schedule 1 to the Building Regulations 2000 (Electrical safety). Guidance is given in Approved Document P.

5.4 Guidance on the selection, installation and maintenance of **sanitary appliances** may be found in BS 6465-3:2006 *Sanitary installations. Code of practice for the selection, installation and maintenance of sanitary and associated appliances*.

5.5 Where hot and cold taps are provided on a **sanitary appliance**, the hot tap should be on the left.

Scale of provision and layout in dwellings

5.6 Any dwelling (house or flat) must have at least one bathroom with a fixed bath or shower, and a washbasin.

5.7 Guidance on the provision of activity space around **sanitary appliances** is given in BS 6465-2:1996 *Sanitary installations. Code of practice for space requirements for sanitary appliances*.

Scale of provision and layout in buildings with rooms for residential purposes

5.8 The number of fixed baths or showers and washbasins in **buildings** with rooms for residential purposes should be in accordance with BS 6465-1:2006 *Sanitary installations. Code of practice for the design of sanitary facilities and scales of provision of sanitary and associated appliances*.

Discharges to drains

Note: See Approved Document for Requirement H1 *Sanitary pipework and drainage* for guidance on provision for traps, branch discharge pipes, discharge stacks and foul drains.

5.9 Any **sanitary appliance** used for personal washing should discharge through a grating, a trap and a branch discharge pipe to an adequate system of drainage.

5.10 A **sanitary appliance** used for personal washing fitted with a macerator and pump may be connected to a small bore drainage system discharging to a discharge stack if:

- a. there is also access to washing facilities discharging directly to a gravity system; and
- b. the macerator and pump meets the requirements of BS EN 12050-2:2001 *Wastewater lifting plants for buildings and sites. Principles of construction and testing. Lifting plants for faecal-free wastewater*.

The Requirement G6

This Approved Document deals with the following requirement from Part G of Schedule 1 to the Building Regulations 2000 (as amended).

<i>Draft requirement</i>	<i>Limits on application</i>
Food preparation areas G6 A suitable sink must be provided in any area where food is prepared.	

DRAFT

DRAFT

Guidance

Performance

In the Secretary of State's view Requirement G6 will be met if a **sink** is provided in any place used for the **preparation of food** (including a **kitchen**).

Where a dishwasher is provided in a separate room, an additional **sink** need not be provided in that room.

Scale of provision in dwellings

6.1 A **sink** should be provided in any **kitchen** or place used for the **preparation of food**.

6.2 Where a dishwasher is provided in a separate room that is not the principal place for the **preparation of food**, an additional **sink** need not be provided in that room.

Scale of provision in buildings other than dwellings

6.3 In all **buildings** other than dwellings, there should be at least the same provision as described in 6.1.

6.4 In **buildings** where the Food Hygiene (England) Regulations 2006 (SI 2006/14) and the Food Hygiene (Wales) Regulations 2006 (SI 2006/31 W5) apply, separate hand washing facilities may be needed. This is in addition to any hand washing facilities associated with WCs in accordance with Requirement G4.

Discharges to drains

Note: See Approved Document for requirement H1 *Sanitary pipework and drainage* for guidance on provision for traps, branch discharge pipes, discharge stacks and foul drains.

6.5 Any **sink** should discharge through a grating, a trap and a branch discharge pipe to an adequate system of drainage.

Annex 1 – Wholesome water

A1.1 For ease of reference, the provisions on the wholesomeness of water in legislation made under section 67 of the Water Industry Act 1991 are set out below. This legislation is subject to Crown copyright protection, and is available in its original form on the United Kingdom Legislation web site, www.opsi.gov.uk/legislation. This web site is managed by Her Majesty's Stationery Office on behalf of the Queen's Printer.

For convenience, the regulations and amendments concerned are reproduced here in a consolidated form. While all efforts have been made to ensure accuracy, the consolidated text should not be regarded as authoritative. In any case of doubt the original regulations and amendments should be consulted.

For reasons of brevity the Schedules and Tables of these Regulations not reproduced here.

Water Supply (Water Quality) Regulations 2000 (SI 2000/3184)

Note: The Water Supply (Water Quality) Regulations 2001 (SI 2001/3911) which apply in Wales contain equivalent requirements.

Wholesomeness

4. (1) Water supplied:
 - a. for such domestic purposes as consist in or include, cooking, drinking, food preparation or washing; or
 - b. to premises in which food is produced, shall, subject to paragraphs (4) and (5), be regarded as wholesome for the purposes of Chapter III, as it applies to the supply of water for those domestic purposes, if the requirements of paragraph (2) are satisfied.
- (2) The requirements of this paragraph are:
 - a. that the water does not contain:
 - i. any micro-organism (other than a parameter) or parasite; or
 - ii. any substance (other than a parameter), at a concentration or value which would constitute a potential danger to human health;
 - b. that the water does not contain any substance (whether or not a parameter) at a concentration or value which, in conjunction with any other substance it contains (whether or not a parameter) would constitute a potential danger to human health;
 - c. that the water does not contain concentrations or values of the parameters listed in Tables A and B in Schedule 1 in excess of or, as the case may be, less than, the prescribed concentrations or values;

d. that the water satisfies the formula $[\text{nitrate}]/50 + [\text{nitrite}]/3 \leq 1$, where the square brackets signify the concentrations in mg/l for nitrate (NO_3) and nitrite (NO_2).

- (3) The point at which the requirements of paragraph (2), in so far as they relate to the parameters set out in Part I of Table A and in Table B in Schedule 1 are to be complied with, is:
 - a. in the case of water supplied from a tanker, the point at which the water emerges from the tanker;
 - b. in any other case, the consumer's tap.
- (4) Water supplied for Regulation 4(1) purposes shall not be regarded as wholesome for the purposes of Chapter III if, on transfer from a treatment works for supply for those purposes:
 - a. it contains a concentration of the coliform bacteria or E. coli parameter (items 1 and 2 in Part II of Table A in Schedule 1) in excess of the prescribed concentrations; or
 - b. it contains a concentration of nitrite in excess of $0.1\text{mgNO}_2/\text{l}$.
- (5) Subject to paragraph (6), water supplied for Regulation 4(1) purposes shall not be regarded as wholesome for the purposes of Chapter III if, on transfer from a service reservoir for supply for those purposes, it contains a concentration of the coliform bacteria or E. coli parameter in excess of the prescribed concentrations.

Private Water Supplies Regulations 1991 (SI 1991/2790)

Wholesomeness

3. (1) This Regulation has effect subject to the provisions of Part III.
- (2) Water supplied to any premises from a private supply for such domestic purposes as consist in or include drinking, washing or cooking or for food production purposes shall be regarded as wholesome for the purposes of Chapter III of Part III of the Water Industry Act 1991, as it applies to the supply of water for any of those purposes, if the requirements of paragraph (3) are satisfied; and, where the water has been softened or desalinated and is supplied for drinking or cooking or for food production purposes, the requirements of paragraph (4) are also satisfied.

- (3) The requirements of this paragraph are:
- a. that the water does not contain any element, organism or substance (other than a parameter) at a concentration or value which would be detrimental to public health;
 - b. that the water does not contain any element, organism or substance (whether or not a parameter) at a concentration or value which in conjunction with any other element, organism or substance it contains (whether or not a parameter) would be detrimental to public health;
 - c. that the water does not have a concentration or value of any parameter listed in Tables A to C in excess of the prescribed concentration or value;
 - d. in respect of any parameter listed in Table D that:
 - i. samples taken over the preceding 12 months in relation to that parameter have established that the average concentration or value did not exceed the prescribed concentration or value;
 - ii. where only one sample is taken in that period in relation to that parameter, the concentration or value did not exceed the prescribed concentration or value; or
 - iii. where no sample is taken in that period in relation to that parameter, the concentration or value for any sample taken in relation to that parameter in the current year does not exceed the prescribed concentration or value;
- e. in respect of trihalomethanes that:
- i. samples taken over the preceding quarter in relation to trihalomethanes have established that the average concentration did not exceed 100 µg/l;
 - ii. where only one sample is taken in that period in relation to that parameter, the concentration did not exceed 100 µg/l; or
 - iii. where no sample is taken in that period in relation to that parameter, the concentration for any sample taken in relation to that parameter in the current quarter does not exceed 100 µg/l.
- (4) The requirements of this paragraph are that the water's hardness and its alkalinity are not below the relevant minimum concentrations specified in Table E.

Annex 2 – Competent person self-certification schemes relevant to sanitation, hot water safety and water efficiency work

- i. Installation of a hot water service system connected to a heat producing gas appliance
Capita Gas Registration and Ancillary Services Limited
Corgi Services Limited
- ii. Installation of a hot water service system connected to an oil-fired combustion appliance
Association of Plumbing and Heating Contractors (Certification) Limited [APHC]
Building Engineering Services Competence Accreditation Limited [BESCA]
NAPIT Registration Limited
NICEIC Group Limited
Oil Firing Technical Association Limited [OFTEC]
- iii. Installation of a hot water service system connected to a solid fuel burning appliance
Association of Plumbing and Heating Contractors (Certification) Limited [APHC]
Building Engineering Services Competence Accreditation Limited [BESCA]
NAPIT Registration Limited
NICEIC Group Limited
Oil Firing Technical Association Limited [OFTEC]
HETAS Limited
- iv. Installation of a hot water service system in a dwelling, other than a combustion appliance
Association of Plumbing and Heating Contractors (Certification) Limited [APHC]
Building Engineering Services Competence Accreditation Limited [BESCA]
CORGI Services Limited
NAPIT Registration Limited
NICEIC Group Limited
- v. Installation of a hot water service system in a building other than a dwelling, other than a combustion appliance
Building Engineering Services Competence Accreditation Limited [BESCA]
NICEIC Group Limited
- vi. Installation of a sanitary convenience, washing facility or bathroom in a dwelling (not involving work on underground drainage)
Association of Heating and Plumbing Contractors (Certification) Limited [APHC]
CORGI Services Limited
NAPIT Registration Limited
NICEIC Group Limited
- For a full and current list of all schemes, consult www.communities.gov.uk

Annex 3 – References

Approved Documents (available at www.planningportal.gov.uk)

Approved Document A – Structure (2004 edition)

Approved Document B (Fire safety) – Volume 1: Dwellinghouses (2006 edition)

Approved Document B (Fire safety) – Volume 2: Buildings other than dwellinghouses (2006 edition)

Approved Document C – Site preparation and resistance to contaminants and moisture (2004 edition)

Approved Document D – Toxic substances (1992 edition)

Approved Document E – Resistance to the passage of sound (2003 edition)

Approved Document F – Ventilation (2006 edition)

Approved Document H – Drainage and waste disposal (2002 edition)

Approved Document J – Combustion appliances and fuel storage systems (2002 edition)

Approved Document J – 2002 Edition: Guidance and supplementary information on the UK implementation of European Standards for chimneys and flues (2004 edition)

Approved Document K – Protection from falling, collision and impact (1998 edition)

Approved Document L1A: Conservation of fuel and power (New dwellings) (2006 edition)

Approved Document L1B: Conservation of fuel and power (Existing dwellings) (2006 edition)

Approved Document L2A: Conservation of fuel and power (New buildings other than dwellings) (2006 edition)

Approved Document L2B: Conservation of fuel and power (Existing buildings other than dwellings) (2006 edition)

Approved Document M – Access to and use of buildings (2004 edition)

Approved Document N – Glazing – safety in relation to impact, opening and cleaning (1998 edition)

Approved Document P – Electrical safety – dwellings (2006 edition)

Relevant legislation (available via www.opsi.gov.uk)

The Building (Approved Inspectors etc.) Regulations 2000 (SI 2000/2532). HMSO, 2000.

The Building Regulations 2000 (SI 2000/2531). HMSO, 2000.

The Food Hygiene (England) Regulations 2006 (SI 2006/14). HMSO, 2006.

The Food Hygiene (Wales) Regulations 2006 (SI 2006/31 W5). HMSO, 2006.

The Gas Safety (Installation and Use) Regulations 1994 (SI 1994/1886). HMSO, 1994.

The Private Water Supplies Regulations 1991 (SI 1991/2790). HMSO, 1991.

The Water Supply (Water Fittings) Regulations 1999 (SI 1999/1148). HMSO, 1999.

The Water Supply (Water Quality) Regulations 2000 (SI 2000/3184). HMSO, 2000.

The Workplace (Health, Safety and Welfare) Regulations 1992 (SI 1992/3004). HMSO, 1992.

The Water Industry Act 1991 HMSO, 1991.

The Health and Safety at Work etc. Act 1974 HMSO, 1974

The European Communities Act 1972 HMSO, 1972

Standards

ANSI-NSF 41-1999. *Non-liquid saturated treatment system*. NSF, 1999.

BS EN 257:1992 *Mechanical thermostats for gas-burning appliances*. BSI, 1992.

BS 417-2:1987 *Specification for galvanized low carbon steel cisterns, cistern lids, tanks and cylinders. Metric units*. BSI, 1987

BS 853-1:1996 *Specification for vessels for use in heating systems. Calorifiers and storage vessels for central heating and hot water supply*. BSI, 1996.

BS EN ISO 1043-1:2002 *Plastics. Symbols and abbreviated terms. Basic polymers and their special characteristics*.

BS EN 1111:1999 *Sanitary tapware. Thermostatic mixing valves (PN 10). General technical specification*. BSI, 1999.

BS EN 1287:1999 *Sanitary tapware. Low pressure thermostatic mixing valves. General technical specifications*. BSI, 1999.

BS EN 1490:2000 *Building valves. Combined temperature and pressure relief valves. Tests and requirements*. BSI, 2000.

BS 1566-1:2002 *Copper indirect cylinders for domestic purposes. Open vented copper cylinders. Requirements and test methods*. BSI, 2002.

BS 3198:1981 *Specification for copper hot water storage combination units for domestic purposes*. BSI, 1981.

BS 4213:2004 *Cisterns for domestic use. Cold water storage and combined feed and expansion (thermoplastic) cisterns up to 500 l. Specification*. BSI, 2004.

- BS 5918:1989 *Code of Practice for Solar heating systems for domestic hot water*. BSI 1989.
- BS 6283-2:1991 *Safety and control devices for use in hot water systems. Specifications for temperature relief valves for pressures from 1 bar to 10 bar*. BSI, 1991.
- BS 6283-3:1991 *Safety and control devices for use in hot water systems. Specification for combined temperature and pressure relief valves for pressures from 1 bar to 10 bar*. BSI, 1991.
- BS 6465-1:2006 *Sanitary installations. Code of practice for the design of sanitary facilities and scales of provision of sanitary and associated appliances*. BSI, 2006
- BS 6465-2:1996 *Sanitary installations. Code of practice for space requirements for sanitary appliances*. BSI, 1996
- BS 6465-3:2006 *Sanitary installations. Code of practice for the selection, installation and maintenance of sanitary and associated appliances*. BSI, 2006
- BS 6700:2006 *Design, installation, testing and maintenance of services supplying water for domestic use within buildings and their curtilages. Specification*. BSI, 2006.
- BS 7291-1:2006 *Thermoplastics pipes and associated fittings for hot and cold water for domestic purposes and heating installations in buildings. General requirements*.
- BS 7291-2:2006 *Thermoplastics pipes and associated fittings for hot and cold water for domestic purposes and heating installations in buildings. Specification for polybutylene (PB) pipes and associated fittings*.
- BS 7291-3:2006 *Thermoplastics pipes and associated fittings for hot and cold water for domestic purposes and heating installations in buildings. Specification for cross-linked polyethylene (PE-X) pipes and associated fittings*.
- BS 7671:2008 *Requirements for electrical installations (IET Wiring Regulations 17th Edition)*.
- BS 8000-15:1990 *Workmanship on Building Sites Code of practice for hot and cold water services (domestic scale)*. BSI, 1990
- BS 8518:2009 *Rainwater harvesting systems, Code of Practice*.
- BS EN 12050-2:2001 *Wastewater lifting plants for buildings and sites. Principles of construction and testing. Lifting plants for faecal-free wastewater*. BSI, 2001.
- BS EN 12897:2006 *Water supply. Specification for indirectly heated unvented (closed) storage water heaters*. BSI, 2006
- BS EN 12976-1:2006 *Thermal solar systems and components. Factory made systems. General requirements*. BSI, 2006.
- prCEN/TS 12977-1:2008 *Thermal solar systems and components. Custom built systems. General requirements*. BSI, 2001.
- BS EN 15092:2008 *Building valves. Inline hot water supply tempering valves. Tests and requirements*. BSI, 2008
- BS EN 60335-2-21:2003 *Household and similar electrical appliances. Safety. Particular requirements for storage water heaters*. BSI, 2003.
- BS EN 60335-2-35:2002 *Specification for safety of household and similar electrical appliances*. BSI, 2002.
- BS EN 60335-2-73:2003 *Specification for safety of household and similar electrical appliances. Particular requirements for fixed immersion heaters*. BSI, 2003.
- BS EN 60730-2-9:2002 *Automatic electrical controls for household and similar use. Particular requirements for temperature sensing controls*. BSI, 2002.

Other documents

- Water Regulations Advisory Scheme. *Water Regulations Guide*. WRAS, 2000.
- WRAS IGN 9-02-04: Issue 1: 1994. *Reclaimed water systems*. WRAS, 1994 (www.wras.co.uk)
- WRAS Information & Guidance Note No. 9-02-05 *Marking and identification of pipework for reclaimed (greywater) systems*. WRAS, 1999 (www.wras.co.uk)
- Market Transformation Project. *Rainwater and greywater: technical and economic feasibility*. MTP, 2007.
- Market Transformation Project. *Rainwater and greywater: a guide for specifiers*. MTP, 2007.
- Market Transformation Project. *Rainwater and greywater: review of water quality standards and recommendations for the UK*. MTP, 2007.
- NHS D08 *National Health Service Model Engineering Specifications Thermostatic Mixing Valves (Healthcare Premises)*. NHS.
- BRE Information paper IP14/03 *Preventing hot water scalding in bathrooms: using TMVs*.
- Food Standards Agency Code of Practice *Food hygiene – a guide for businesses*. (www.food.gov.uk)
- English Heritage publication *Building Regulations and Historic Buildings, 2002 (revised 2004)*, (www.english-heritage.org.uk)
- European Council Directive 89/106/EEC, *The Construction Products Directive*.
- European Council Directive 93/68/EEC, *The CE Marking Directive*.
- The Code for Sustainable Homes, December 2006*, www.planningportal.gov.uk

HSC publication *Legionnaires' Disease: Control of Legionella Bacteria in Water Systems. Approved code of practice and guidance.* L8, Health and Safety Commission 2000. ISBN 0717617726

CIBSE Commissioning Code M: *Commissioning Management*, CIBSE, 2003. ISBN 1 90328 733 2

Health and Safety Commission, *Workplace health, safety and welfare, Approved code of practice*, HMSO 1992.

DRAFT

DRAFT

DRAFT

DRAFT

DRAFT

DRAFT

DRAFT

DRAFT

DRAFT

APPROVED DOCUMENTS

The following documents have been approved and issued by the First Secretary of State for the purpose of providing practical guidance with respect to the requirements of the Building Regulations 2000 (as amended).

Approved Document A: Structure
2004 edition

**Approved Document B (Fire safety) –
Volume 1: Dwellinghouses**
2006 edition

**Approved Document B (Fire safety) –
Volume 2: Buildings other than dwellinghouses**
2006 edition incorporating 2007 amendments

**Approved Document C: Site preparation and
resistance to contaminants and moisture**
2004 edition

Approved Document D: Toxic substances
1992 edition

**Approved Document E: Resistance to the
passage of sound**
2003 edition

Approved Document F: Ventilation
2006 edition

**Approved Document H: Drainage and
waste disposal**
2002 edition

**Approved Document J: Combustion
appliances and fuel storage systems**
2002 edition

**Approved Document J: 2002 edition:
Guidance and Supplementary Information
on the UK Implementation of European
Standards for Chimneys and Flues**
2004 edition

**Approved Document K: Protection from falling
collision and impact**
1998 edition

**Approved Document L1A: Conservation of
fuel and power (New dwellings)**
2006 edition

**Approved Document L1B: Conservation of
fuel and power (Existing dwellings)**
2006 edition

**Approved Document L2A: Conservation of
fuel and power (New buildings other than
dwellings)**
2006 edition

**Approved Document L2B: Conservation
of fuel and power (Existing buildings other
than dwellings)**
2006 edition

**Approved Document M: Access to and use
of buildings**
2004 edition

**Approved Document N: Glazing – safety in
relation to impact, opening and cleaning**
1998 edition

**Approved Document P: Electrical safety
– dwellings**
2006 edition

**Approved Document to support Regulation 7:
Materials and workmanship**
1992 edition incorporating 2000 amendments

DRAFT

Published by NBS, part of RIBA Enterprises Ltd, and available from:

RIBA Bookshops Mail Order

15 Bonhill Street
London EC2P 2EA

Telephone orders/General enquiries: 020 7256 7222

Fax orders: 020 7374 2737

Email orders: sales@ribabookshops.com

Or order online at:

www.thenbs.com/buildingregs

DRAFT

RIBA Bookshops

RIBA, 66 Portland Place, London W1B 1AD. Telephone 020 7256 7222

Birmingham & Midland Institute, Margaret Street, Birmingham B3 3SP. Telephone 0121 233 2321

RSUA, 2 Mount Charles, Belfast BT7 1NZ. Telephone 02890 323 760

CUBE, 113-115 Portland Street, Manchester M1 6DW. Telephone 0161 236 7691

milkandsugar, 82 Wood Street, Liverpool L1 4DQ. Telephone 0151 707 4380

ISBN 978 1 85946 323 9

Stock code 68817

© Crown Copyright, 2009

Copyright in the typographical arrangement rests with the Crown.

This publication, excluding logos, may be reproduced free of charge in any format or medium for research, private study or for internal circulation within an organisation. This is subject to it being reproduced accurately and not used in a misleading context. The material must be acknowledged as Crown copyright and the title of the publication specified. This document/publication is value added. If you wish to re-use, please apply for a Click-Use Licence for value added material at www.opsi.gov.uk/click-use/system/online/pLogin.asp, or by writing to the Office of Public Sector Information, Information Policy Team, Kew, Richmond, Surrey TW9 4DU. Email: licensing@opsi.gov.uk. If you require this publication in an alternative format please email alternativeformats@communities.gsi.gov.uk.

nbs

www.thenbs.com

ISBN 978-1859463239



9 781859 463239